



TOHATSU OUTBOARD MOTOR

M2.5A/M3.5A

SERVICE MANUAL



AUG 1988

CONTENTS

	page
I. 1 Specifications	5
2-1 General precautions.....	6
-2 Service tools and measuring instruments.....	7
II. Main Features	9
III. Stripping, servicing and reassembling	10
1. Detaching auxiliary equipment.....	10
2. Disassembling power head.....	13
3. Inspection of parts.....	15
4. Assembling the power head.....	16
5. Stripping and reassembling of gear case.....	17
6. Drive shaft housing.....	19
7. Bracket.....	20
8. Recoil starter.....	21
9. Carburetor.....	22
10. Electrical equipment.....	24
11. Separate tank kit.....	29
12. Battery charging adapter kit.....	30
IV. Trouble shooting and servicing	33
1. Trouble shooting.....	33
2. Propeller setting.....	34
3. Test running.....	35
4. Service data.....	37
5. Sealing, bonding and lubrication points.....	38
V. Periodical check	40

FOREWORD

To get the maximum amount of pleasure and performance out of an outboard motor it is important that you understand the functions of the mechanism and learn to operate the controls with ease and confidence. This service manual will explain the construction of the "TOHATSU" M2.5A and M3.5A outboard motors and the best way to carry out periodical overhauls and maintenance. The information is based on the models produced in August 1981., but as "TOHATSU" follows a policy of continuous product improvement, it reserves the right to make changes to specifications without prior notice.

August 1988

TOHATSU CORPORATION

M3.5A ENGINE PERFORMANCE

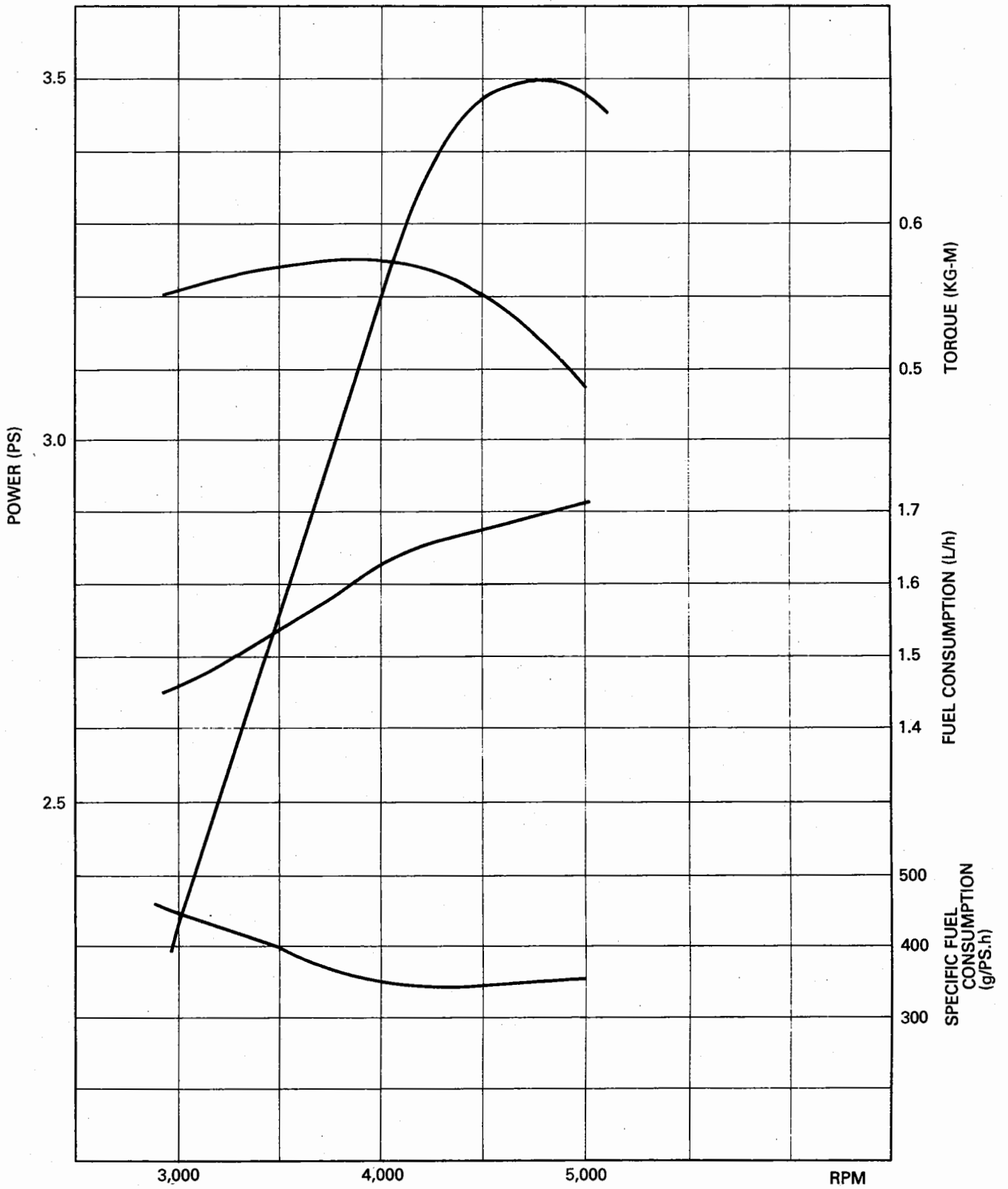

M2.5A ENGINE PERFORMANCE

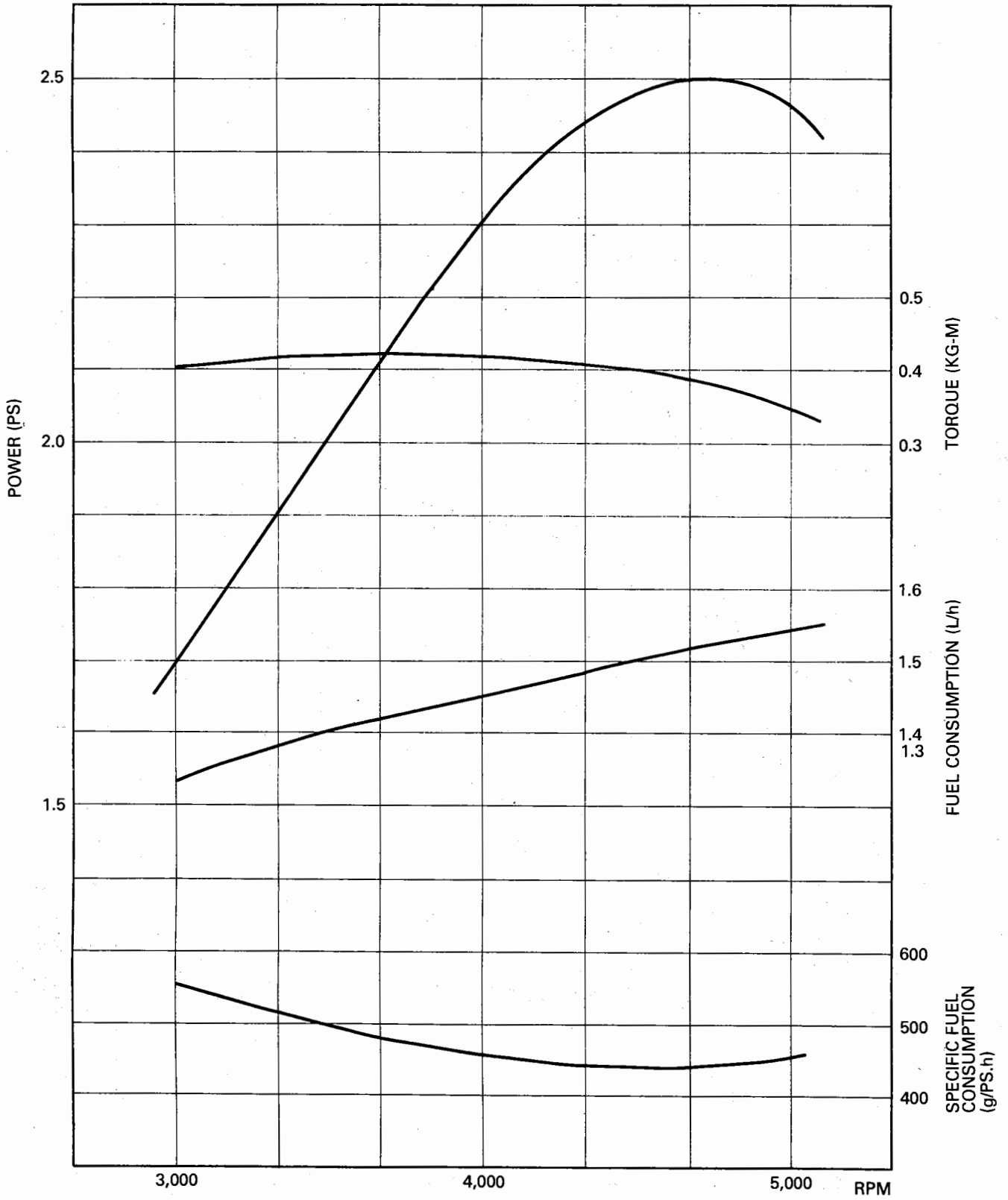

I. SPECIFICATIONS M2.5A/M3.5A

DATA SHEET

Model	M3.5A	M2.5A
Overall length	Approx. 550 mm	
Overall width	Approx. 195 mm	
Overall height	Approx. 955 mm (transom 15") Approx. 1,082 mm (transom 20")	
Weight	Approx. 12.5 kg (transom 15")	
Engine Type	WT47B	
Piston displacement	74.6 cc (4.6 cu.in.)	
Power output	3.5 PS	2.5 PS
Lubrication	Gasoline/Oil Mixture	
Cooling method	Water cooling (rotary rubber impeller)	
Starting	Automatic recoil starter & rope	
Ignition	Flywheel magneto	
Spark plug	NGK BP6HS10 or CHAMPION L87YC10	
Carburetor	Cross-shaft Butterfly Valve Type	
Engine rotation	Clockwise	
Maximum running speed	4,300~5,000r.p.m.	3,800~5,200r.p.m.
Fuel consumption at maximum speed	1.7 ℓ/h	
Reduction ratio	13 : 24	
Propeller (No. of blades x dia. x pitch)	2 x 180 mm x 166 mm	3 x 188 mm x 110 mm
Speed control	Throttle lever	
Steering method	Bar handle	
Gear shift	Nil. 360° pivot turn	
Fuel tank capacity	1.4 ℓ	
Gear case oil capacity	90 cc	

OPTIONAL PARTS

Lighting coil	Available 12V-40W
Separate Tank	Available 13 ℓ
Rectifier	Available

II. GENERAL PRECAUTIONS

M2.5A/M3.5A

This chapter details the procedures for stripping servicing, and re-assembling the engine and the drive unit. During this work, the following precautions should be kept in mind.

1. GENERAL PRECAUTIONS

- (1) When servicing the motor, secure it firmly to work bench.
- (2) While working on the motor, care should be taken that painted surfaces, inside and matching surfaces of cylinders and crankcase are not damaged or scratched.
- (3) Packings, gaskets, O-rings, spring pins, bent washers and cotter pins should be replaced every time the engine is stripped down. Also replace any deformed snap rings.
- (4) Always use TOHATSU genuine parts and TOHATSU outboard motor oil or oil recommended by TOHATSU.
- (5) Only use the special tools specified. Never use any other tools. Servicing must be carried out in a correct and accurate manner according to this manual.
- (6) When stripping any assembly, take special note of the match marks. If no match marks can be seen, it is advisable to make your own so that mistakes are not made when reassembling the parts.
- (7) Small parts, bolts, nuts and washers, when they have been removed, should be temporarily placed in their original positions so that they are not lost.
- (8) All parts as they are stripped down should be cleaned and washed with detergent oil and checked for wear and damage carefully. This does not apply to rubber items, which could be damaged by gasoline.
- (9) During reassembling, take note of the fitting of matching parts, packings, wiring and piping as well as greasing, centering, and sealing.
- (10) Bolts and nuts (e.g., cylinder head and crankcase) should be tightened progressively in a criss-cross pattern from inner side to outer side. (Loosening should be carried out in the reverse order.)
- (11) When installing an oil seal, care should be taken not to scratch the oil seal lip. Make sure not to reverse its true position. (Fig. 1-1)
Be sure to pack the oil seal cavity with the specified grease.
- (12) Be sure to apply the proper amount of liquid packing agent. If too much agent is used, it may overflow into the crankcase or elsewhere. Before using adhesives, read the directions carefully.
- (13) If any bolt or nut is hard to remove because of rust, spray on liquid loosening agent (Three Loosen) or some similar preparation and wait more than five minutes for the oil to penetrate the threads.
- (14) For service data, tightening torques, and correct application of sealing agents, adhesives and grease, please refer to the following sections of this chapter.
- (15) Key to symbols used in this manual.

H820-2	Hexagon bolt	Diameter 8mm	Length 20mm	Quantity 2
G8-2	Hexagon nut	Diameter 8mm		Quantity 2
G8-2	Hexagon nut (3 kinds)	Diameter 8mm		Quantity 2
W6-2	Plain washer	Inside Dia. 6mm		Quantity 2
SW6-2	Spring washer	Inside Dia. 6mm		Quantity 2
P620-2	Pan head screw	Diameter 6mm	Length 20mm	Quantity 2

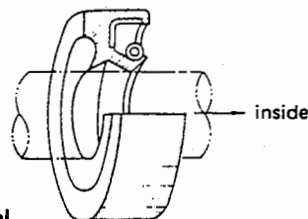

(Fig. 1-1) Oil seal

2. SERVICE TOOLS AND MEASURING INSTRUMENTS

The following service tools and measuring instruments are required for servicing TOHATSU outboard motors. (Fig. 2-1)

Be sure to use the special tools when noted as "use special tool".

1. General Tools

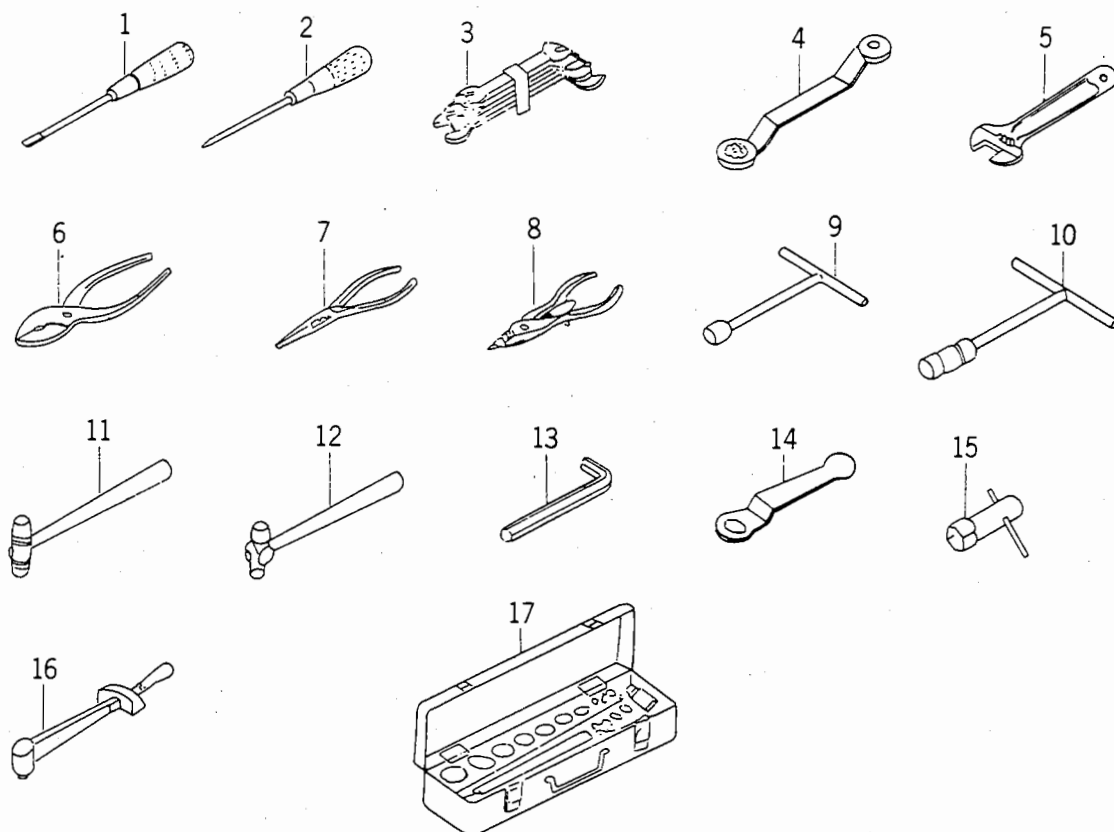

(Fig. 2-1) General tools

(1) Slotted-head screwdriver	(200mm)	(9) T-handle socket wrench	(10mm)
Slotted-head screwdriver	(150mm)	T-handle socket wrench	(13mm)
Slotted-head screwdriver	(100mm)	T-handle socket wrench	(17mm)
(2) Phillips-head screwdriver	(200mm)	(10) T-handle universal wrench	(10mm)
Phillips-head screwdriver	(150mm)	T-handle universal wrench	(13mm)
Phillips-head screwdriver	(100mm)	(11) Plastic-head hammer	
(3) A set of open-end wrenches	(16 sizes)	(12) Hammer	3/4 lb
(4) Box wrench	(10 x 13mm)	(13) Allen Key	(8mm)
Box wrench	(17 x 21mm)	Allen Key	(10mm)
Box wrench	(21 x 23mm)	(14) Spark plug wrench	(21mm)
(5) Adjustable wrench	(300mm)	(15) Spark plug wrench	(21mm)
(6) Pliers		(16) Torque wrench	(500kg-cm)(1500kg-cm)
(7) Long-nose pliers		(17) Socket wrench set	
(8) Clip pliers		(18) Piston ring tool	

2. Special tools

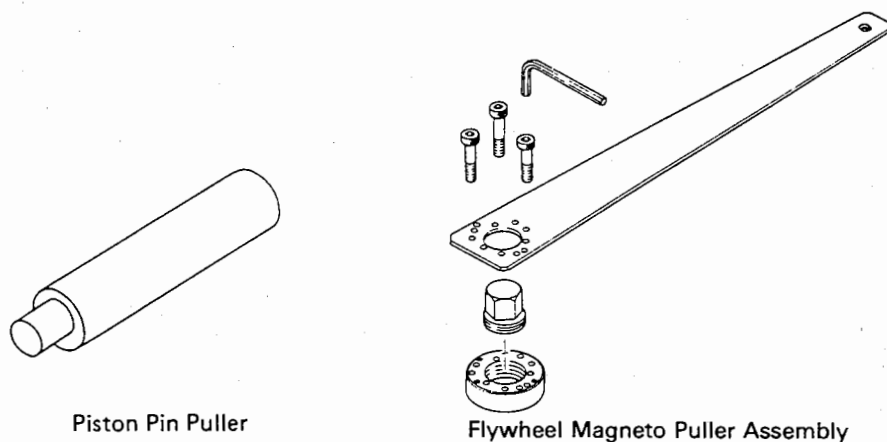

Piston Pin Puller

Flywheel Magneto Puller Assembly

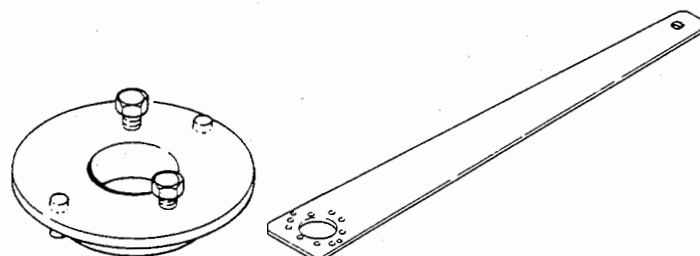

Magneto Nut Tool Ass'y

3. Compression gauge (0 ~ 14kg/cm²)

4. Test propeller

5. Measuring instruments

The following instruments are available on the market:

Tachometer	600 ~ 10,000rpm or TOHATSU tachometer
Universal tester	(Resistance x 1,100, 10KΩ, AC voltage 30 ~ 300V, DC voltage 30V, Battery 3V or less)
Vernier calipers	(JIS B7507 M1 type vernier calipers 300mm)
Micrometer	(JIS B7502, 0.01mm scale, outside micrometer)

Cylinder gauge	(JIS B7515, 50 ~ 100mm scale cylinder gauge)
Ring gauge (mm)	(JIS B7420, 70φ)
Dial gauge	(JIS B7503, 0.01mm scale)
Feeler gauge	(JIS B7524 0.03 ~ 0.3mm measurements)
V-blocks	(JIS B7540)
Surface plate	(JIS B7513, 500 x 500mm)
Dial gauge magneto base or dial gauge stand	
Megger-meter	500 or 1000V megger

II. MAIN FEATURES

M2.5A/M3.5A

1. The excellent performance of the good-looking M2.5A/M3.5A outboard motor shows up at all times—even when cruising in a rough sea.
2. Its specifications make it suitable for both pleasure and commercial purposes. Special attention has been given to engine reliability and safety characteristics.
3. Materials have been chosen for their durability and appearance. Full use is made of plastics and die-cast aluminum. Anodic protection is given to metal parts to prevent corrosion and it maintain its original appearance.
4. The engine has been designed to be light yet without sacrificing performance and durability. The weight of Transom S model is only 12.5 kgs. The M2.5A/M3.5A is easy to handle, and is fitted with handling brackets for transportation and fitting.
5. The carburetor has a special device to prevent fuel leakage when the engine is tilted. It is completely protected against sea spray. The throttle knob and choke knob are conveniently placed near to the carburetor in order to simplify operation.
6. Very little vibration is transmitted to the steering handle because of the damping characteristics of the mounting.
A steering adjusting screw allows you to select the steering response of your choice.
7. The components of the outboard motor have been simplified in order to make inspection and servicing easy.
8. The M3.5A leads its class for speed — 14.5 km/h for a 3 meter FRP boat with two persons.
9. When fitted to a 3m FRP boat the motor will run at about 50 mins at full throttle when the 1.4 liter overhead fuel tank has been completely filled.
If a lighter boat is used, then the cruising range will be extended over 12 km.
10. The submerged exhaust system reduces noise to a minimum. Carburetor inlet noise is also silenced. A typical noise level is 63 dBs at a distance of 25 m.
11. Optional fuel tanks are available for special applications. If the 13 liter tank is fitted the motor will have a cruising time of 8 hrs while running at full speed.
12. Lighting equipment is available as an option with outputs up to 40 watts at 12 volts.
13. A rectifier kit is available which permits the on-board charging of storage batteries.

III. STRIPPING, SERVICING AND REASSEMBLING

M2.5A/M3.5A

1. DETACHING AUXILIARY EQUIPMENT

When dismantling and servicing the motor, first detach the top cover, plug cap cover, fuel tank, carburetor and magneto.

- (1) Close the air vent of the fuel tank cap and the fuel cock. (Fig. 1-1)
- (2) Remove the plug cap cover by pulling it downwards. (Fig. 1-2)
- (3) Remove the right and left motor covers. (Fig. 1-3)
(Attaching screw: 7 each side and 2 on top).
- (4) Remove the fuel tank.
 - Disconnect the fuel pipe before dismantling the fuel tank. (Fig. 1-4)
- (5) Remove the recoil starter and detach the starter pulley attached to the magneto. (Fig. 1-5)

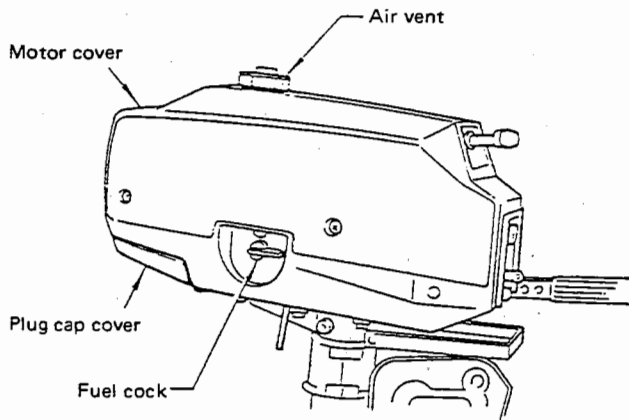

(Fig. 1-1)

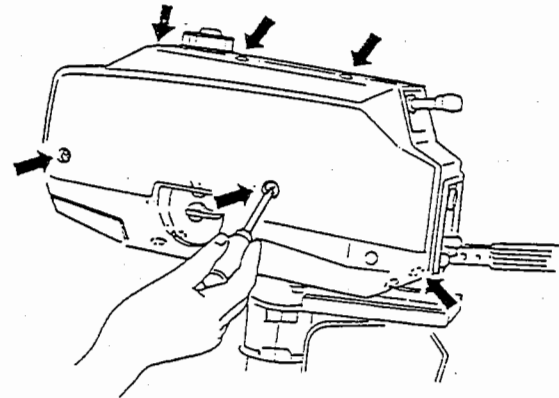

(Fig. 1-3) Removing the motor covers

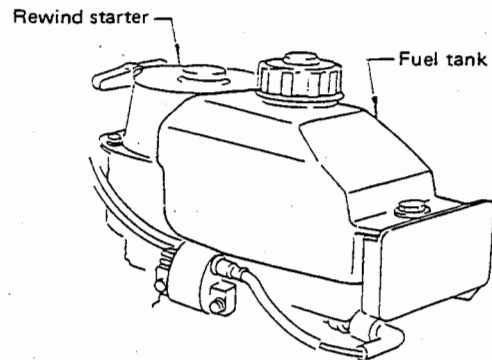

(Fig. 1-4) Removing the fuel tank

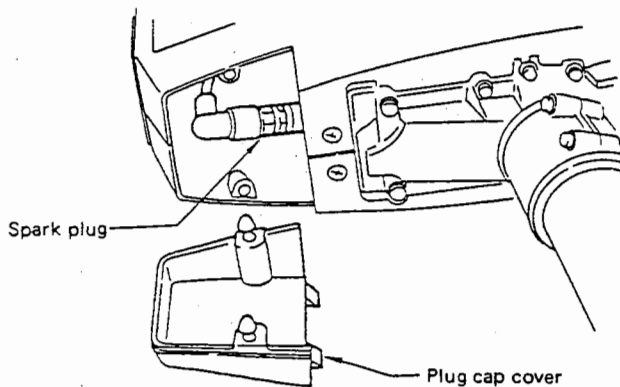

(Fig. 1-2)

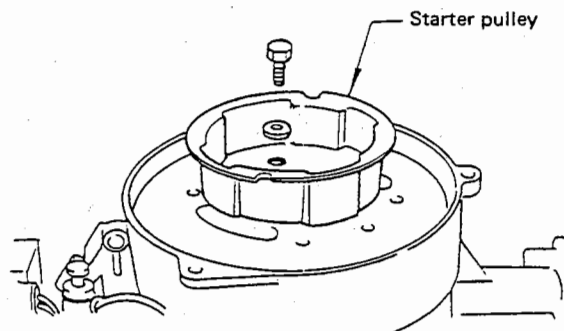

(Fig. 1-5) Removing the starter pulley

(6) Remove the magneto nut using the special flywheel puller. (Fig. 1-6)

∴ The magneto nut has a clockwise thread. Turn counterclockwise to remove.

(Tightening torque: 4 ~ 4.5 kg-m)

(7) Withdraw the magneto flywheel. (Fig. 1-7)

MAKE SURE that you use the SPECIAL FLY-WHEEL MAGNETO TOOL.

(8) Disconnect the magneto primary lead (black/white), stop switch cord (black/white) terminal and detach the magneto base.

∴ Remove the magneto key from the keyway also, and store in a safe place. (Fig. 1-8)

(9) Remove the carburetor. (Fig. 1-9)

(10) Remove the six engine mounting bolts and remove the engine from its base. (Fig. 1-10)

∴ The drive shaft is connected inside the engine body. Be careful not to withdraw it from the lower part of the motor when removing the engine.

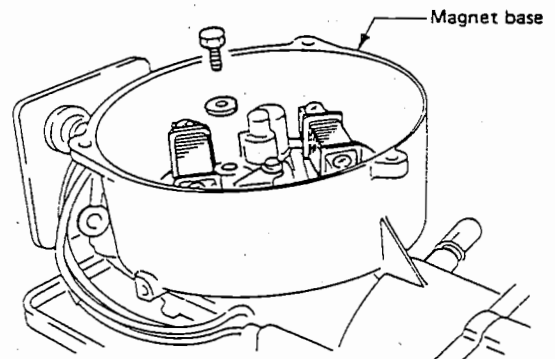

(Fig. 1-8) Removing the magneto base

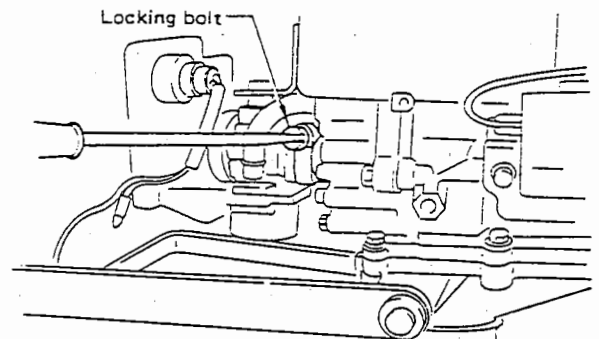

(Fig. 1-9) Removing the carburetor

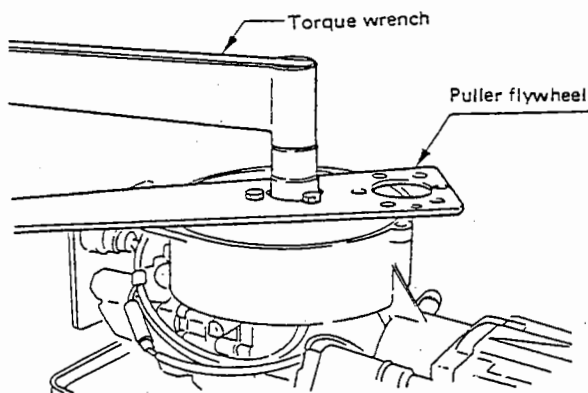

(Fig. 1-6) Removing the magneto nut

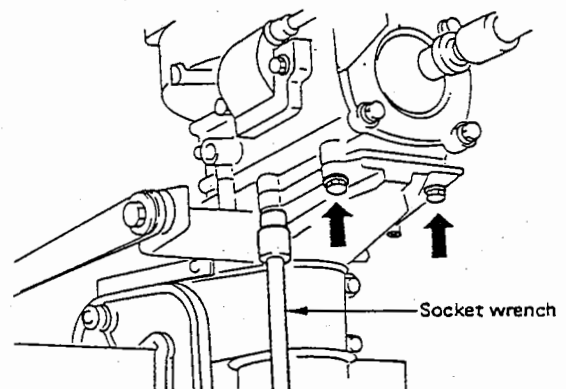

(Fig. 1-10) Dismounting the engine

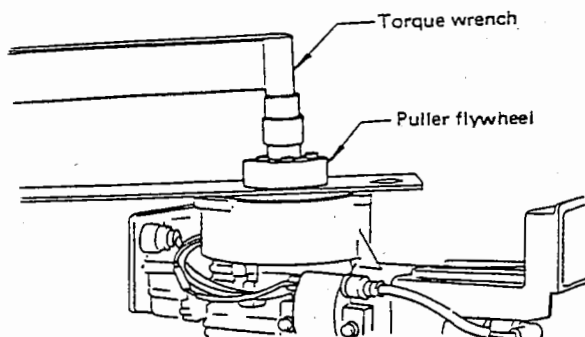

(Fig. 1-7) Detaching the flywheel

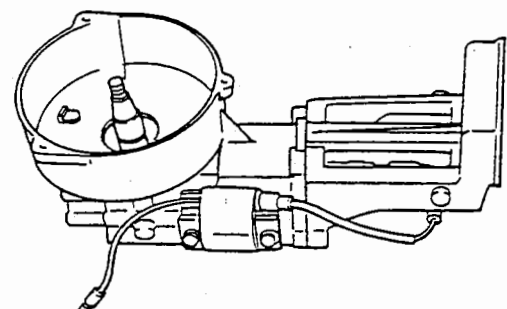

(Fig. 1-11) Power unit

(11) Assembling

Assembling is carried out in the reverse order of stripping. In this case give attention to the following points.

- Make absolutely certain that the carburetor body gasket is inserted when attaching the carburetor.
- Carry out ignition point gap adjustment after the flywheel has been fitted. (Gap 0.3 ~ 0.4 mm)
- When fitting the magneto flywheel and the starter pulley first position the flywheel using the key. Then tighten by means of the magneto nut (clockwise thread) using the special tool (flywheel puller). When fitting the starter pulley use

the retaining bolt after tightening the magneto nut.

- When fitting the starter take care that tightening is carried out methodically so that the starter click does not contact with the starter pulley.
- When attaching the engine covers take care that the high tension cable and fuel pipes are not pinched by the covers.
- Connect the stop switch cord to the magneto-side of the primary coil.
- Replace the new drive shaft housing gasket everytime it is reassembled.

2. DISASSEMBLING POWER-HEAD

Carry out the stripping and inspection of the engine parts individually.

• Stripping the engine

- (1) Remove the crankcase head.
 - Remove the gasket. (Fig. 2-1)
- (2) Remove the cylinder head.
 - Remove the cylinder gasket. (Fig. 2-2)

- (3) Remove the cylinder & crankcase. (Fig. 2-3)
- (4) Detach the crankshaft assembly. (Fig. 2-4)
- (5) Detach the reed valve. (Fig. 2-5)
- (6) Reed valve assembly (Fig. 2-6)

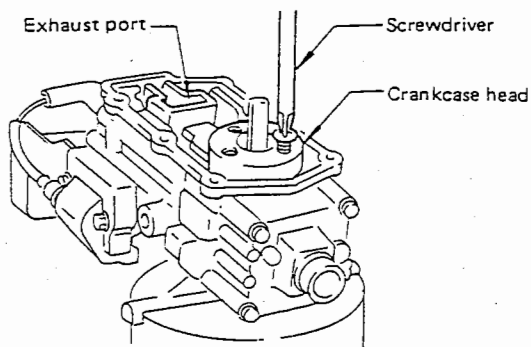

(Fig. 2-1) Removing the crankcase head

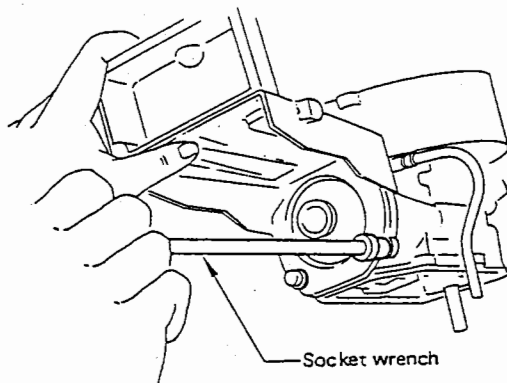

(Fig. 2-2) Removing the cylinder head

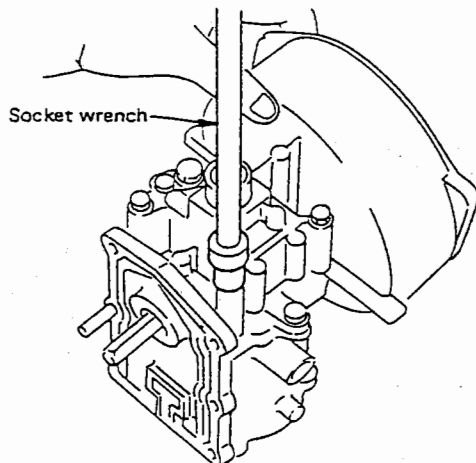

(Fig. 2-3) Removing the cylinder & crankcase

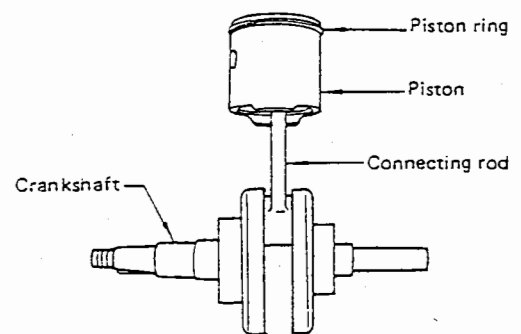

(Fig. 2-4) Crankshaft assembly

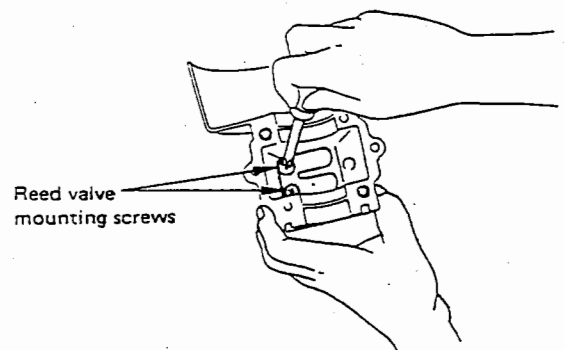

(Fig. 2-5) Detaching the reed valve

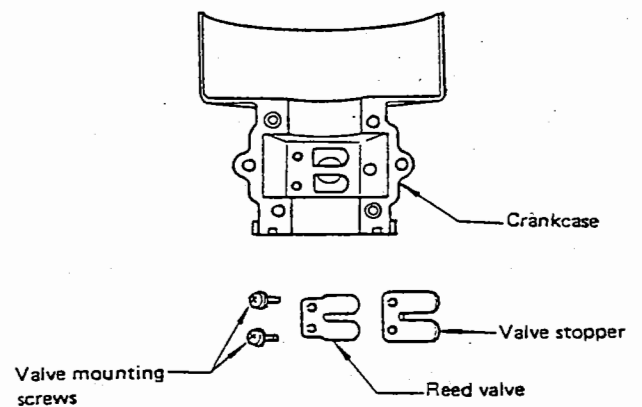

(Fig. 2-6) Reed valve assembly

Fig. 2-7 Power unit construction

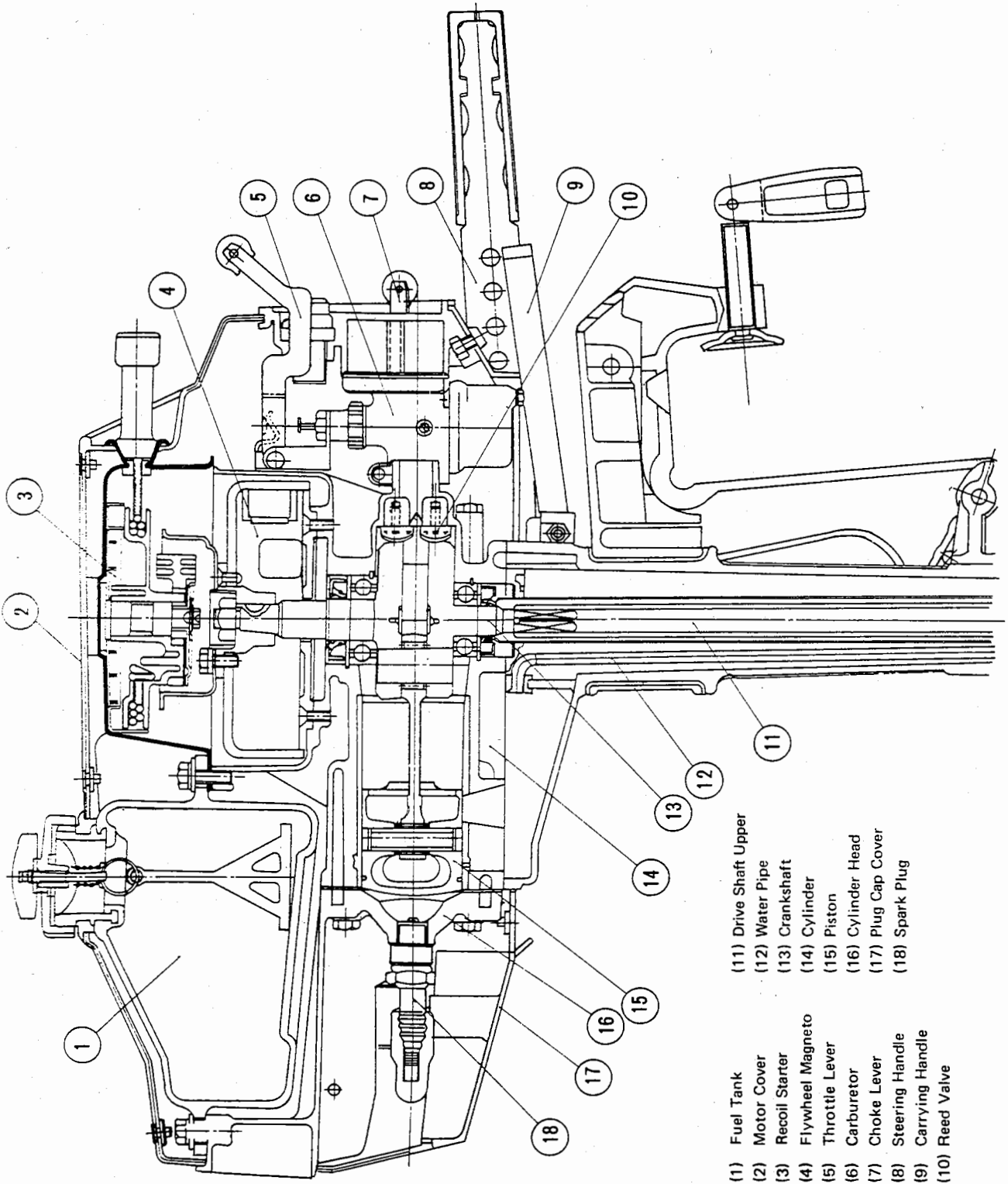

- (1) Fuel Tank
- (2) Motor Cover
- (3) Recoil Starter
- (4) Flywheel Magneto
- (5) Throttle Lever
- (6) Carburetor
- (7) Choke Lever
- (8) Steering Handle
- (9) Carrying Handle
- (10) Reed Valve
- (11) Drive Shaft Upper
- (12) Water Pipe
- (13) Crankshaft
- (14) Cylinder
- (15) Piston
- (16) Cylinder Head
- (17) Plug Cap Cover
- (18) Spark Plug

3. INSPECTION OF PARTS

Part Number	Check Point	Remedy
Cylinder head	<ol style="list-style-type: none"> 1. Carbon deposits in combustion chamber 2. Warpage of cylinder head sealing surface 3. Corrosion on cylinder head sealing surface 4. Clogging of cooling water passages 	<ol style="list-style-type: none"> 1. Clean. 2. Correct. (Place sandpaper #200 on surface plate and rub cylinder head against it.) 3. Correct or replace it as required. 4. Clean.
Cylinder	<ol style="list-style-type: none"> 1. Carbon deposits around exhaust port 2. Build-up of salt deposit in water jacket 3. Wear in cylinder bore. Measure bore with cylinder gauge to determine piston clearance. 4. Engine seizure 5. Scored or scuffed cylinder walls 	<ol style="list-style-type: none"> 1. Clean. 2. Clean. 3. If wear exceeds limits, replace or rebore and hone. Replacement pistons and piston rings are available in 0.5 oversize. 4. Replace or after boring, fit oversize pistons. 5. Remove scratches using sandpaper #400 – #600.
Piston	<ol style="list-style-type: none"> 1. Carbon deposits on piston crown and ring grooves 2. Scratches on piston 3. Piston ring clearance 4. Wear in piston pin hole 5. Wear in piston skirt 	<ol style="list-style-type: none"> 1. Clean. 2. Remove using sandpaper #400 – #600. 3. Replace if it exceeds maximum limits. 4. Replace if it exceeds maximum limits. 5. Replace if it exceeds maximum limits.
Piston ring	<ol style="list-style-type: none"> 1. Ring end gap If no ring gauge is available, measure the ring end gap by placing ring in lower part of cylinder where wear is least. 2. Width and thickness 	<ol style="list-style-type: none"> 1. Replace if it exceeds maximum limits. 2. Replace if they reduces minimum limits.
Crankshaft	<ol style="list-style-type: none"> 1. Deflection of crankshaft 2. Deflection of connecting rod 3. Side gap at big end 4. Wear in small end 	<ol style="list-style-type: none"> 1. Repair or replace if it exceeds maximum limits. 2. Replace if it exceeds maximum limits. 3. Replace if it exceeds maximum limits. 4. Replace if it exceeds maximum limits.
Reed valve	<ol style="list-style-type: none"> 1. Height of valve stopper 2. Cracked or damaged reeds 3. Deformation of valve seat 	<ol style="list-style-type: none"> 1. Correct. 2. Replace. 3. Replace.
Anode	<ol style="list-style-type: none"> 1. Lower drive shaft housing side anode 	<ol style="list-style-type: none"> 1. Replace as required.

4. ASSEMBLING THE POWER HEAD

(1) Correctly insert the crankshaft plate in the groove of the crankcase. (Fig. 4-1)

(2) Assembling the crankshaft

- Fitting the piston . . . Join it to the little end of the rod using the piston pin in such a manner that the arrow mark on the top of the piston is on the exhaust port side and then secure the pin by means of the piston pin locking ring. (Make sure that you use new piston pin locking ring).

- Fitting the piston ring to the piston. (Note the stop knock in the piston ring groove which prevents piston ring rotation).

- Assembling main bearing crankshaft oil seal (lower and upper).

Main bearing No.:

Upper: 6004ZE2C3

Lower: 6204ZE2C3

The oil seal must be fitted so that the spring lip portion is on the inside and the inside of the lip must be smeared with grease.

- Apply engine oil to the piston, piston ring and bearing.
- Fit the crankshaft assembly to the cylinder block.
- Insert the main bearing knock in the positioning groove of the cylinder.
- Confirm that the crankshaft assembly is correctly positioned by lightly turning it by hand.

(3) Assembling the crankcase

- Assemble the reed valve and valve stopper.

⊙ Precautions to be taken when fitting the reed valve

Check the reed valves for damage, scratches and burrs. Fix it using the mounting bolt centering it and the valve stopper the sheet suction port. (Reed valve stopper. Height: 6 ~ 6.2 mm)

(Fig. 4-3)

- Apply the liquid gasket agent to the contacting surfaces of the crankcase.

- Fit it to the cylinder using the 2 knocks and attach the crankcase by means of the mounting bolts.

- Check the crankshaft by lightly turning it with your hands.

(4) Fitting the cylinder head

- Use new gasket.

(5) Fitting the crankcase head

- Fit it with the notch of the crankcase head positioned on the cooling water inlet side.

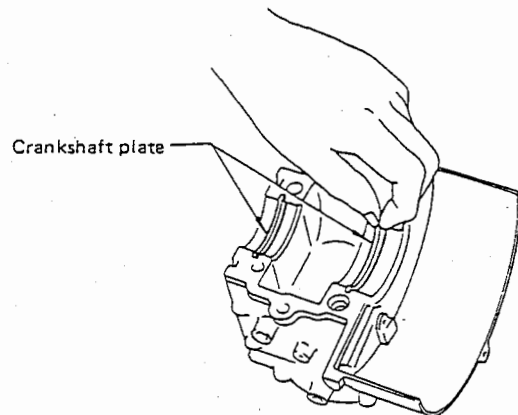

(Fig. 4-1) Attaching the crankshaft plate

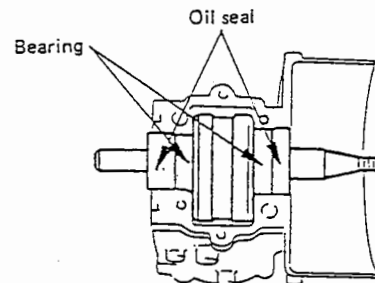

(Fig. 4-2) Assembling the crankshaft

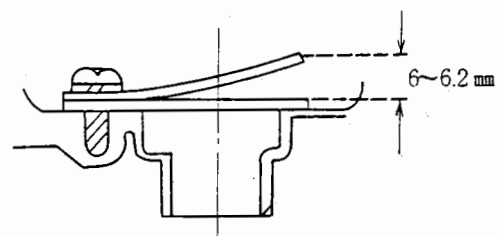

Height of the top portion of Reed Valve Stopper

(Fig. 4-3) Assembling the reed valve

5. STRIPPING AND REASSEMBLING OF GEAR CASE

• Stripping

- (1) Pull out the split pin and remove the propeller and the shear pin. (Fig. 5-1)
- (2) Loosen and remove the gear case bolt (H630), detach the drive shaft housing and then remove the gear case assembly. Then detach the drive shaft guard pipe and the drive shaft upper. (Fig. 5-2)
- (3) Remove the gear case cap bolt (H620) and the gear case (Fig. 5-3)
- (4) Pull off the water pump impeller and the impeller key. (Fig. 5-4)
- (5) Detach the water pump case. (Fig. 5-5)
- (6) Lift up the drive shaft lower and pull off the bevel gear. (Fig. 5-6)
- (7) Remove the propeller shaft assembly. (Fig. 5-7)

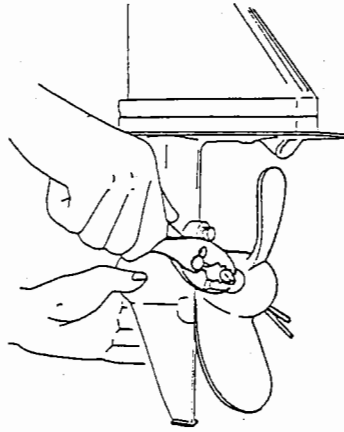

(Fig. 5-1) Removing the propeller

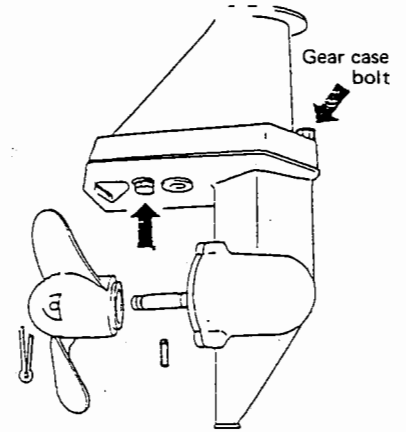

(Fig. 5-2) Removing the gear case assembly

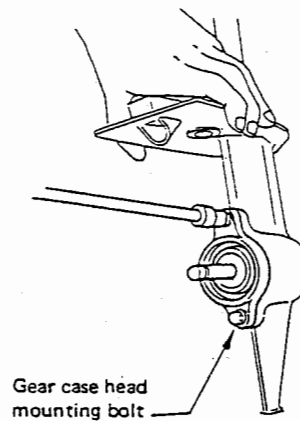

(Fig. 5-3) Removing the gear case cap

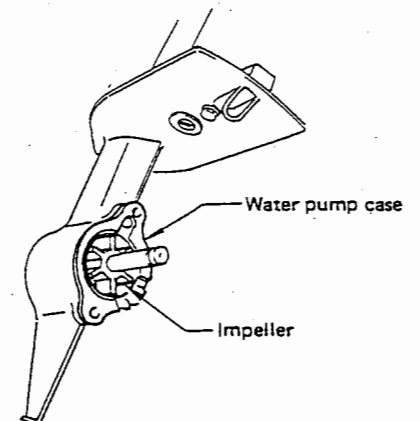

(Fig. 5-4) Detaching the water pump impeller

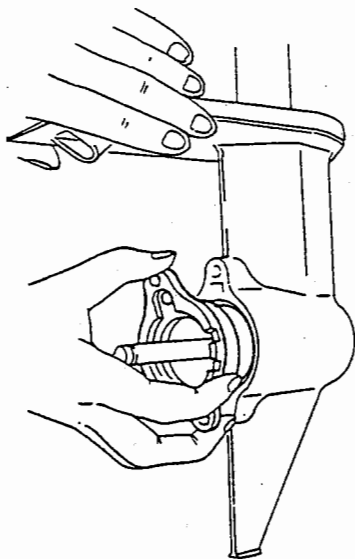

(Fig. 5-5) Removing the water pump case

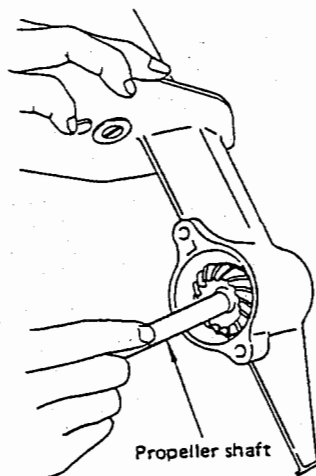

(Fig. 5-6) Detaching the bevel gear B

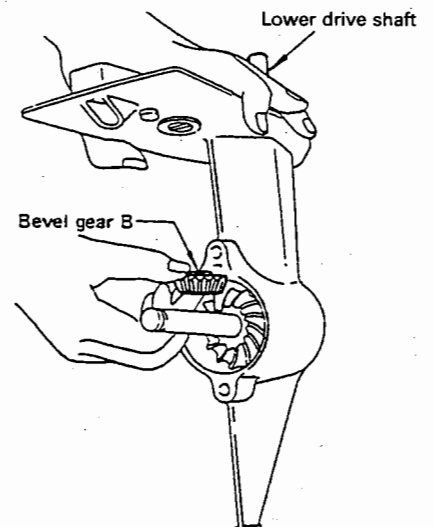

(Fig. 5-7) Detaching the propeller shaft

Assembling

Assembling is carried out in the reverse order of stripping.

- When assembling the water pump impeller take care that the impeller is replaced with the blades in their correct direction and that the direction of rotation is correct.
- When assembling replace the water pump case 'O' ring with a new one.

Gear case oil capacity: 90 cc

Inspection items and actions to be taken when assembling

Part name	Inspection items	Remedy
Bevel gear A and B	1. Check the click for wear. 2. Check gear contact. 3. Check the bearing face for wear.	1. Replace. 2. Replace if necessary. 3. Replace if necessary.
Propeller shaft	1. Check the shear pin hole for wear. 2. Check the oil seal inner lip for wear and damage.	1. Replace if necessary. 2. Replace if necessary.
Drive shaft	1. Check the oil seal inner lip for wear and damage. 2. check the lip for wear and damage.	1. Replace. 2. Replace.
Oil seal (Propeller shaft) (Drive shaft)	1. Check lip for wear and damage.	1. Replace.
Bearing (Propeller shaft) (Drive shaft)	1. Check for wear. 2. Check for smoothness of rotation.	1. Replace if necessary. 2. Replace if necessary.

Fig. 5-8 Gear Case Construction

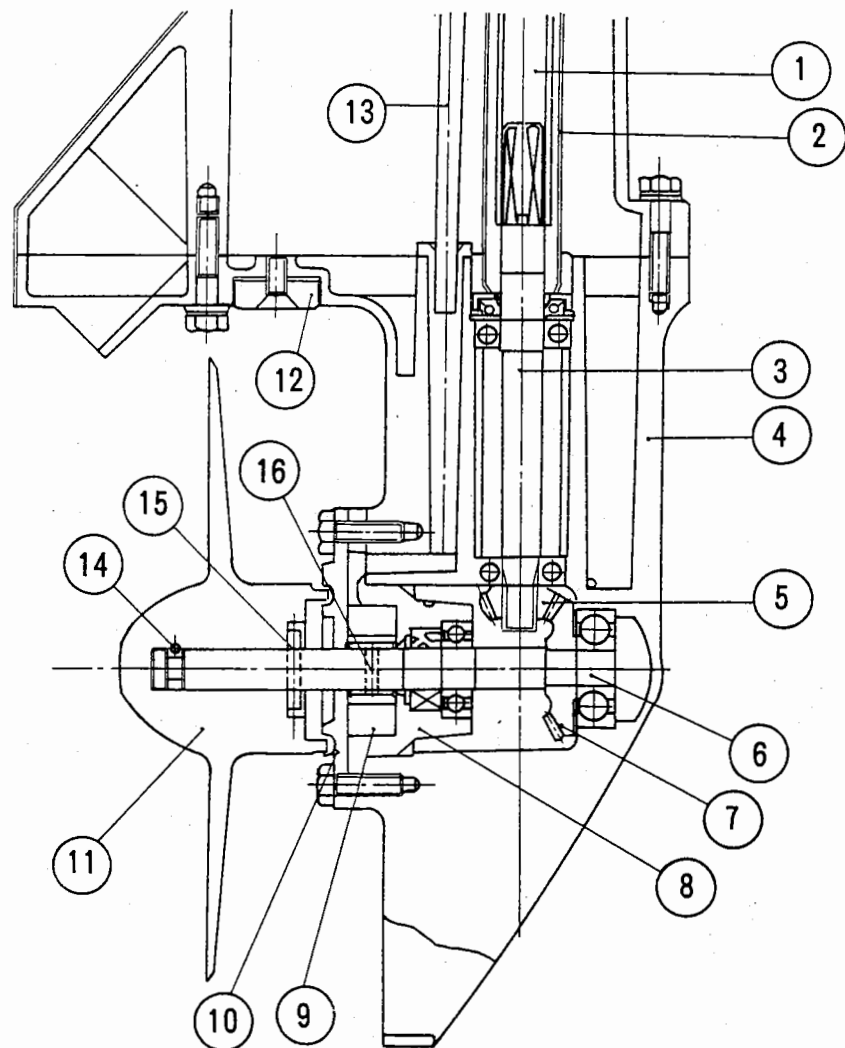

- (1) Drive shaft upper
- (2) Drive shaft guard pipe
- (3) Drive shaft lower
- (4) Gear case assembly
- (5) Bevel gear B
- (6) Propeller shaft assembly
- (7) Bevel gear A assembly
- (8) Water pump case
- (9) Water pump impeller
- (10) Gear case cap
- (11) Propeller
- (12) Anode
- (13) Water pipe
- (14) Split pin
- (15) Shear pin
- (16) Pump impeller key

6. DRIVE SHAFT HOUSING

- Carry out after detaching the engine and gear case.
- 1 Remove the swivel bracket bolt and then detach the drive shaft housing. (Fig. 6-1)

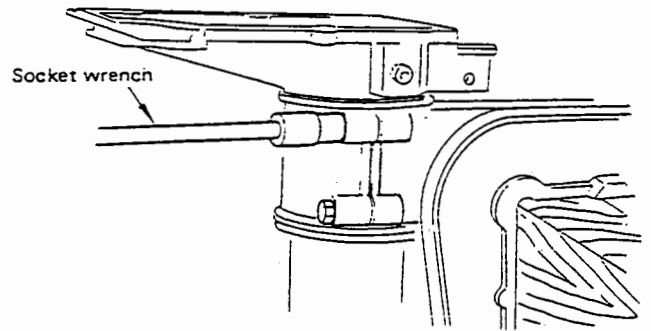

(Fig. 6-1) Removing the drive shaft housing

Inspection

Inspection items	Remedy
<ul style="list-style-type: none">• Check the drive shaft bearing for salt deposits and wear.• Check the thrust surface of the drive shaft housing for wear.• Check the drive shaft housing gasket for damage.	<ul style="list-style-type: none">• Apply grease or replace if required.• Replace if necessary.• Replace.

7. BRACKET

- Carry out after having removed the drive shaft housing.

(1) Remove the thrust supporter bolt. (Fig. 7-1)

(2) Remove the stern bracket bolt. (Fig. 7-2)

- Assembling

Assembling is carried out in the reverse order of stripping. Apply grease to the inside surface of the swivel bracket and the pivot bushing when assembling.

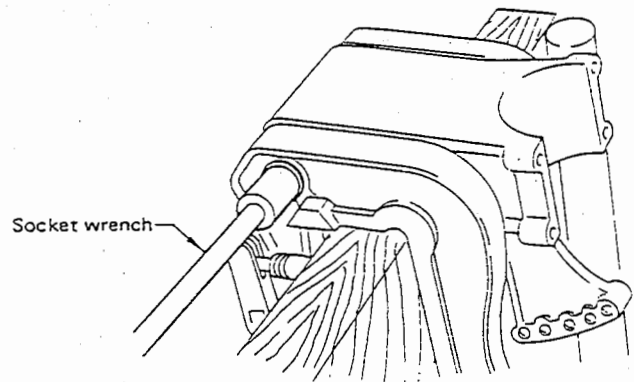

(Fig. 7-1) Detaching the thrust supporter bolt

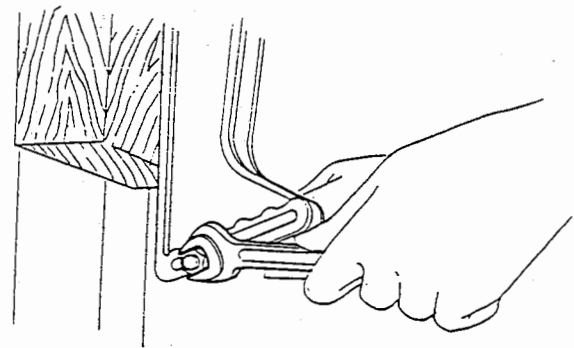

(Fig. 7-2) Detaching the stern bracket bolt

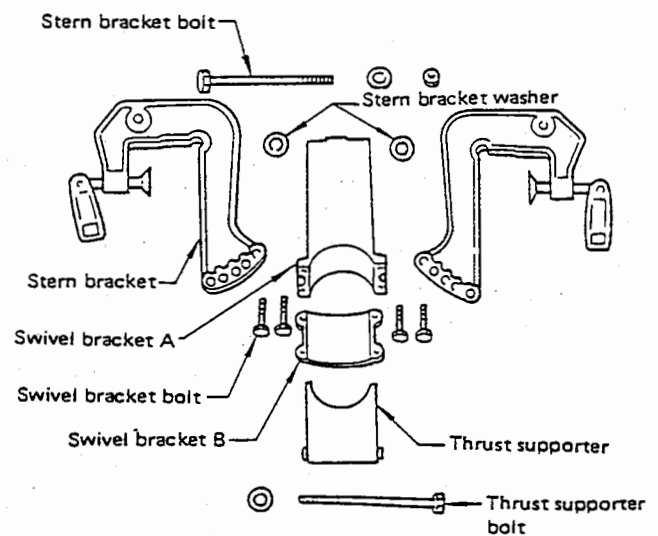

(Fig. 7-3) Bracket

8. RECOIL STARTER

The starter of this motor is an automatic recoil type. When the rope is pulled, a ratchet engages with the rim of the starter pulley thus turning the crank shaft. When the engine has started or the rope is released, the ratchet automatically disengages and the rope returns to its original position in the starter case.

Stripping

- 1) Remove the motor cover and detach the starter from the engine after having loosened the three starter mounting bolts.
- 2) Pull out the rope a short distance and insert it in the notch of the case and then slowly loosen the starter spring.
- 3) First detach the E ring and the friction plate and then detach the ratchet.
- 4) Detach the return spring and then remove the reel.

(Fig. 8-1)

Assembling

Assembling is carried out in the reverse order of stripping. However, give due attention to the following points.

- 1) When setting the starter spring, wind it counterclockwise after attaching the outer end to the recessed portion of the reel.
- 2) Wind the rope counterclockwise as seen from the reel side, pass the rope through the hole of the starter case and fix it to the starter handle after having wound it twice counterclockwise.
- 3) When attaching the ratchet make sure that the tooth is facing the right direction.
- 4) Adjustment of the starter spring tension is carried out after the assembly has been completed by inserting the rope in the notch of the reel, turning counterclockwise and winding the rope four times around the reel.

- Starter rope tension

When the rope has been pulled out 30 cm

$$2 \pm 0.7 \sim 0.8 \text{ kg.}$$

- 5) If a chattering noise is heard when the starter assembly has been attached and the engine started, stop the engine, loosen the mounting bolts and retighten after having varying the position little until a position has been reached where the noise has been eliminated.
- 6) Lubricate the following places: Shaft (inside the starter case) ratchet and starter spring.

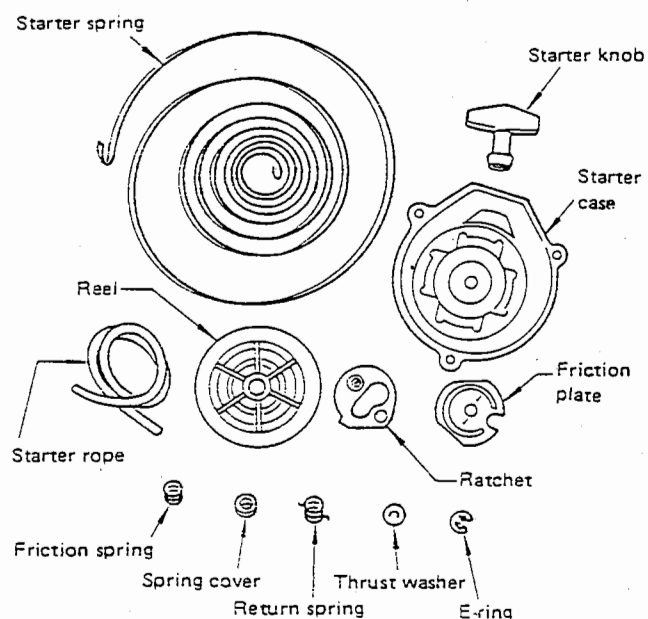

(Fig. 8-1) Individual parts of the rewind starter

9. CARBURETOR

The function of the carburetor is to deliver the correct mixture of fuel and air to the engine under all conditions of speed and load. The engine is fitted with the K13PA-1A carburetor manufactured by TK carburetor Co., Ltd. and this is fastened to the inlet port of the cylinder by a clip and screw which simplifies servicing. The carburetor draws its air from inside the motor cover thus preventing dust and water from entering the engine. The throttle valve is operated by a throttle cable connected to the throttle lever and the choke valve is controlled by the choke lever.

The function of the carburetor is to mix the air and fuel in the correct ratio and feed this mixture to the engine.

- It is important to produce a air-fuel mixture in which the fuel is atomized since this aids combustion.

Construction of the carburetor

The main component parts of the carburetor are as follows:—

(1) Float chamber

The float chamber houses the float hinge, float hinge pin and needle valve and these keep the fuel level at the correct height in the chamber, when the fuel flows into the float chamber through the needle valve. When the fuel level reaches the correct height in the chamber the needle is tightly held against its seat and cuts off the flow of fuel

into the chamber.

As the fuel is used up by the engine and the fuel level drops, the float falls and the pressure is relieved on the needle valve. This allows fuel to fill the chamber once more and this action is repeated continuously to keep the fuel level at its rated height at all times.

(2) Outlet and cutaway

These function in transfer from low speed to high speed when fuel cannot be drawn up because throttle valve is not open enough and that the negative pressure on needle jet is small, the gas mixture is drawn up and supplied to the engine.

The less cutaway is, the more the negative pressure is increased and the thicker the gas mixture is.

(3) Jet needle and main jet

As the throttle rises in the carburetor body, the tapered needle withdraws from the main jet. So, as more air passes through the air intake, more fuel is drawn up and mixed with the air. Since the needle can be raised or lowered in relation to the throttle, a richer or leaner mixture can be obtained.

For this purpose the jet needle is provided with four grooves, and its height can be adjusted by a needle collar and a spring clip to obtain the best high speed running condition.

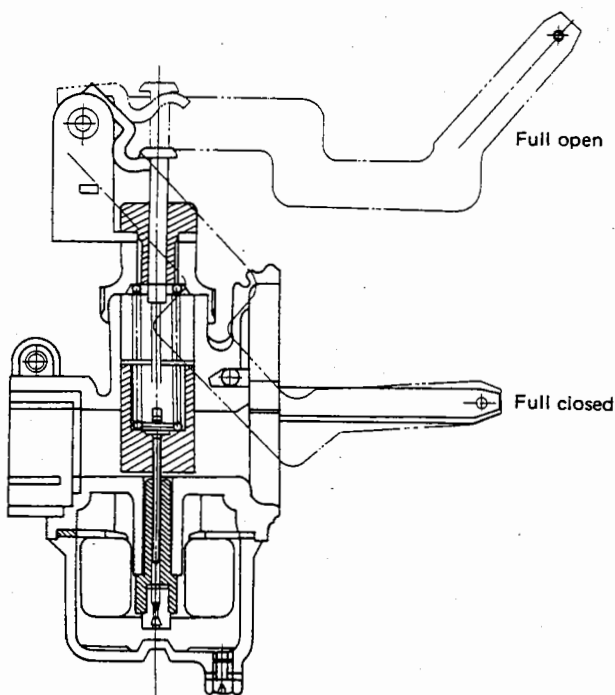

Precautions when fitting the carburetor

- Care must be taken that there are no air leaks between the carburetor and the cylinder inlet port. Make sure that the carburetor is vertical and that it is correctly tightened by the screw and clip.
- Fuel and air passages must be kept clean. Dust, grit and corrosion will cause poor running and rapid wear.
- Do not clean with wire or similar matter since this may scratch or enlarge the jet holes and so upset the air-fuel mixture ratio, and cause poor engine performance.
- Replace worn parts as soon as they are detected, since these will cause faulty operation.
- If you wash parts with gasoline or similar volatile liquids blow dry with an air blast before assembling.
- Be careful not to lose the fuel needle valve when taking the float chamber apart.

When the assembly has been completed the following points must be taken care of.

- Note that the float arms rest lightly on the float, until the fuel needle is pressed hard against the needle valve seat.

Carburetor adjustment

If the mixture provided by the carburetor is too rich or too lean poor running will result.

Too rich mixture	Too lean mixture
<ul style="list-style-type: none"> ○ The engine speed does not pick up well. ○ The spark plug may suffer dry and wet fouling. It has black deposits of carbon. ○ When the choke valve is closed during operation the engine performance tends to get poorer. 	<ul style="list-style-type: none"> ○ The engine runs roughly and misfiring occurs. ○ The engine easily overheats. The insulated tip of the plug is white, glazed or glossy and deposits on the tip are melted. ○ When the choke valve is partially closed at the time of running the engine speed increases and engine performance improves.

If the above symptoms are present, check the points given below.

Too rich mixture	Too lean mixture
<ul style="list-style-type: none"> ○ Wear of individual parts (such as main jet and jet needle). ○ Too high fuel level in chamber (poor operation and wear in needle valve and float tab). ○ Air bleed blocked by dirt. ○ Make sure that the choke is opened as soon as the engine is running normally. 	<ul style="list-style-type: none"> ○ Fuel system passages blocked by dirt. Check cock, main jet and needle valve seat. ○ Too low fuel level in chamber (poor operation of the float valve). ○ Air leakage due to the improper fitting of the carburetor.

- 1) Idling adjustment (Throttle opened less than 1/8)
Turn the slow running adjusting screw one turn clockwise, then start the engine. Return the throttle lever to its closed position and adjust the screw until the correct speed is obtained. Turn the screw clockwise to increase speed, counterclockwise to reduce rpm.
- 2) Adjustment of main jet (Throttle opened 1/4 ~ 3/4)
The carburetor is correctly adjusted when it leaves the factory and it is not advisable to alter it unless this is absolutely necessary. The main jet needle is held in position in the throttle by means of a spring clip which fits into one of four grooves. Moving the clip to a higher groove will make the mixture leaner, and moving the clip down will produce a richer mixture.

Carburetor specifications

Part name	Specifications
Main jet	#88
Needle jet	ϕ 2.080 wh 1.5mm w ϕ 2.5
Jet needle	#0.71 2/4 step
Throttle valve cut-away	0.75mm
Hole diameter of valve seat	ϕ 1.4
Fuel level (from the venturi center)	21 \pm 1mm

10. ELECTRICAL EQUIPMENT

1. MAIN PARTS

Items	Part name	Type standards	Maker	Remarks
Ignition	Flywheel magneto	FOTO 1374	Mitsubishi Electric	Plug gap: 0.9~1.0 mm
	Spark plug	NGK BP6HS-10 Champion L87YC-10	Nippon Tokushu Togyo Co. Champion	
Switch	Safety switch			Waterproof type
Lighting	Bulb lamp	12V 40W	Stanley Electric	
	Lighting coil		Mitsubishi Electric	
	Plug socket for lighting use		Mitsubishi Electric	
Charging	Rectifier			

2. WIRING DIAGRAM (Fig.10-2)

3. DESCRIPTION—FLYWHEEL MAGNETO

The ignition device is provided with the flywheel-type magneto Model FOTO 1347 manufactured by Mitsubishi Electric Co., Ltd. The low tension current generated by the magneto is fed into a condenser, and the charge is abruptly interrupted by the contact breaker and fed into the primary winding of the ignition coil. This induces a high tension current in the secondary coil of the ignition coil.

3-1. Flywheel and cam

(1) Construction

The flywheel is a steel bowl type provided with highly efficient ferrite magnets and pole shoes firmly fixed inside by screws or adhesive. The 4 poles are magnetized in a radial direction as seen from the center of the flywheel. The cam is fitted to the flywheel shaft and the slipper arm of the contact breaker slides against the surface of the cam. As the cam rotates the points of the contact breaker open and close.

(2) Inspection and servicing

Check for play. Tap it lightly with a hammer and check the ring. A crank shaft will have a distinctive sound. When mounting the flywheel on the tapered shaft make sure surfaces are clean and free from burrs. Do not apply grease or oil to the tapered surface.

3-2. Magnet base plate

(1) Construction

The elements of the magneto are bolted to the aluminum alloy magneto base. These include the condenser, exciting coil, ignition coil and contact breaker.

(2) Condenser

The condenser serves to store the electric charge and to release it to the ignition coil as the ignition points open. If the coil is faulty it will cause arcing across the points, which will soon become in-serviceable. The potential available in the secondary winding of the ignition coil will also be much reduced.

- Testing the condenser (Fig. 16-3)

To test the condenser remove the retaining screw and lift the condenser off the base plate so that it is solely supported by its wire. With a multi-tester set at 0 ~ 1 MΩ touch the two terminals of the condenser. If the needle moves slightly and then immediately returns to its original position the condenser can be regarded as serviceable. The condenser is also sound if it has an insulation resistance of over 5 MΩ using a megger-meter. When it has been charged by the megger the condenser is normal if a spark jumps between the center terminal and the case when short-circuited.

(3) Contact breaker

The contact breaker interrupts the exciting current supplied to the primary winding of the ignition coil by

opening and closing the points on the breaker arm and base plate. It is mounted on the magneto base plate.

Contact surface area of points:

Over 1/2 of the contact area.

Contact pressure: 600 ~ 800 gr (slipper)

Insulation resistance of the breaker terminal:

(Measured at the center of the contact surface)

Over 5 M Ω at room temperature, 500V megger.

Other service points to be checked on the contact breaker

Smooth operation of the breaker arm:

To clean the contact points cut a small strip of # 800 grit emery paper and fold with the sanded surfaces facing outwards. Place between the contact points and gently polish the contact surfaces. If there is excessive metal removed from the points or if the slipper is abnormally worn the contact pressure of the spring will be reduced. In this case the contact breaker should be replaced. Make sure that all grit is removed from between the contact points after cleaning.

○ Measuring the contact breaker pressure (Fig. 10-4)

It is important that the breaker arm follows the cam when the engine is running at high speeds, since, if the arm "floats" poor engine performance may result. The contact arm pressure is checked by a spring balance attached to the slipper, and this should register at least 400 grams. Poor performance will also result if the terminals or securing screws are loose, or if the gap is too large, or if the spring has been strained.

To check the insulation resistance of the contact breaker open the points and place a piece of paper between them. Then, using either a multi tester or megger take a reading between the breaker terminal and the magneto base plate. Using either a 500V or 1000V megger, if the value exceeds 5 M Ω the contact breaker assembly can be assumed to be serviceable, although this will depend on the strength of the withstand current. (Fig. 10-5)

(4) Oiling felt

The oiling felt lubricates between the cam and breaker slipper in order to reduce the wear on the slipper mounted on the breaker arm. If the felt is not in contact with the cam, or if the felt has not been impregnated with oil, it cannot do its job.

○ Servicing standards

Arrange the felt pad so that it is lightly in contact

with the lowest part of the cam when the tip of the felt is fully extended.

(5) Ignition coil

The ignition coil supplies the high voltage charge to the spark plug. It can produce a charge in the 10,000 ~ 20,000 volt range.

The ignition coil is built round a core made up of a lamination of silicon and steel plates. One end of the primary coil is grounded to the magneto based plate, while the other end is provided with a lead to the exciter coil which is led through the laminated steel core via a glass insulated bush.

The secondary coil is wound concentrically round the primary coil, with one end connected to the primary lead, and the other to the H.T. spark plug lead.

Most troubles in ignition coils are due to short circuits in the primary or secondary windings due to defective insulation, overheating or interior damage. TOHATSU coils are built to very high standards.

And coils after winding, are heat-dried and thoroughly impregnated with resin to increase their resistance to moisture and improve their withstand voltage characteristics.

● Method of measuring by tester

The winding resistance check must also be carried out even when the coil is checked by the tester.

● Standard values

Primary winding resistance: 0.5 Ω \pm 15%

Secondary winding resistance: 500 Ω \pm 15%

○ Checking method (Fig. 10-6, 7)

The coil is checked by a circuit tester. When measuring the primary winding resistance measure the resistance between the ignition coil, the primary coil lead wire terminal (bipolar coupler portion) and the magneto base plate with the tester set at the minimum range.

When measuring the secondary winding resistance measure the resistance between the plug cap terminal at the end of the high tension cable and the core or ignition coil bracket with the resistance changeover range set at 100 Ω .

If the measured resistance value of the secondary winding is much lower than the standard value given above an interwinding short-circuit should be suspected as the cause. If the reading is much higher than a broken or fused wire may be the cause. In both cases it will be necessary to replace the defective ignition coil.

4. STOP SWITCH

(1) Inspection and servicing

Moisture or dirt inside the stop switch will cause a drop in the insulation resistance value and the engine will become difficult to start. To measure the insulation value disconnect the two connectors and take the reading between these two leads. With the tester set at its

maximum resistance range, a reading of $2\text{ M}\Omega$ will indicate the switch to be serviceable.

If a 500V megger is used, a $2\text{ M}\Omega$ reading shows that the switch is in normal operating condition. Keep the interior of the switch dry and clean. Should the switch cover be cracked or damaged replace it with a new one.

5. SPARK PLUG

(1) Checking and servicing

Check that a specified spark plug is used. Clean the interior of the plug to remove carbon and adjust the gap by bending the other electrode. If the electrodes are worn, replace the plug. Make sure that a gasket is fitted, since this is necessary to dissipate the heat correctly, and to ensure a gas-tight joint. Make sure that the plug is tightened securely, but not too tight. Check the outside insulator for cracks, and make sure that any similar deposits adhering to the outer surface are removed, since these would impair the performance of the plug.

● Servicing standards

Insulation resistance: Over $10\text{ M}\Omega$ at room temperature 500V megger,

Electrode gap: $0.6 \sim 0.7\text{ mm}$ measure by a clearance gauge.

Tightening torque: $2.5 \sim 3.0\text{ kg}\cdot\text{m}$.

● Checking the spark plug insulation

Take the reading between the plug code and the HT cord terminal using at 500V or 1000V megger.

In correcting the spark plug gap use a wire feeler type plug gap gauge. When adjusting the gap always bend the outer (ground) side electrode, never the center electrode. The gap is correct when there is a slight resistance between the gauge and the electrodes.

If the spark gap is too large the magneto can not produce enough potential (demand voltage) to bridge the gap and cause the mixture to fire.

A too small gap also causes incomplete combustion of the air/fuel mixture, and causes poor engine performance.

There is also a similar fall off of power when a dirty, worn or damaged spark plug is used.

(2) Ignition timing adjustment

In the case of this motor the indication or the measurement of the ignition timing is carried out by displacement of piston. The ignition timing regulating works are carried out in the following order.

First set the piston position using the dial gauge and regulate in such a manner that at this point the contact

breaker begins to open.

After having completed the regulation measure the clearance between the contacts and confirm that the measured value is within the reference value.

● Servicing reference value

Ignition timing

piston displacement top dead center reference: $1.6\text{ mm} \pm 0.4$

crank angle before top dead center: $20^\circ \pm 2$

Clearance between the contact points of the contact breaker: $0.35 \pm 0.05\text{ mm}$

(3) Checking method of ignition timing

Since the ignition timing indicates the piston position at the moment when the magneto's ignition voltage begins the spark discharge through the spark plug, it is expressed by the displacement from the piston's upper dead center or crank angle.

Since the spark discharge of the spark plug is generated at the moment when the contacts of the contact breaker open if the displacement of the piston is measured at the point where the piston begins to open the measured value indicates the ignition timing.

○ Detaching the recoil starter and spark plug

Slowly turn the flywheel clockwise while viewing the piston through the plug detaching screw hole and stop when the piston comes near the upper dead center and then fit the dial gauge holder and the dial gauge to the plug mounting screw. In this case the reading of the gauge must be $6 \sim 7\text{ mm}$.

○ When measuring the ignition timing connect the one terminal of the timing tester to the magneto's stop wire terminal (which is connected to the stop switch terminal on the rear of the stop switch) and ground the other terminal.

○ Obtain the upper dead center of the piston by means of the gauge pointer and coincide the "0" scale of the gauge with the pointer.

● When obtaining the upper dead center by means of the pointer of the gauge obtain the upper most position of the piston by means of the gauge

pointer before hand and at this position coincide the "0" scale with the pointer.

The correct upper dead center is the center between the position where the pointer reaches 2 scales before the "0" point (0.02 mm approx. 1°) by slowly turning the flywheel counter-clockwise by 10° and then turning clockwise, and the other position where the same pointer reaches the 2 scales before the "0" point again after having passed the upper dead center by further turning the flywheel to the right.

At this point coincide the "0" scale of the gauge with the pointer which provides the reference for the measurement of the ignition timing.

(4) Method of regulating the ignition timing

The regulation of the ignition timing is carried out by adjusting the clearance between contacts.

Since the base plate of this type is fixed by means of 2 counter-sunk screws the ignition timing can be regulated by merely adjusting the clearance between the contacts. Carry out regulation of the clearance between the contacts by slowly turning the crank shaft clockwise (on the upper dead center side) after having assembled the flywheel.

Loosen the contact base regulating screw (Fig. 10-1) by means of (-) screwdriver, move the contact base and coincide the clearance with 0.35 ± 0.05 using the clearance gauge and then tighten the screw.

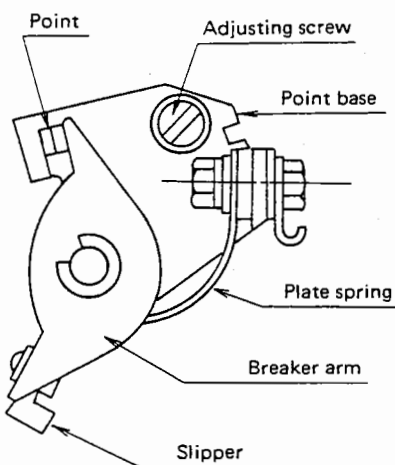

(Fig. 10-1) Contact breaker

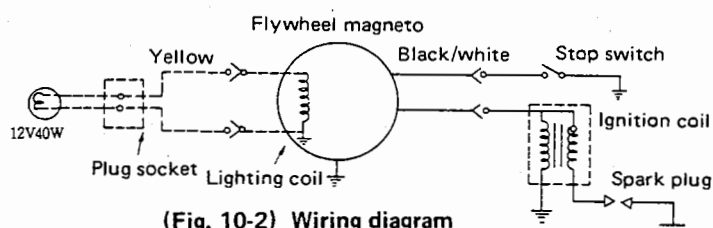

(Fig. 10-2) Wiring diagram

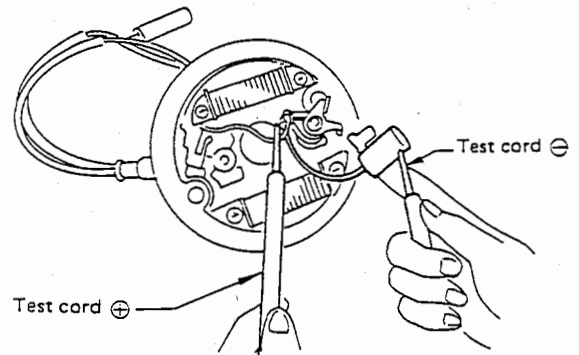

(Fig. 10-3) Measuring capacity of condenser

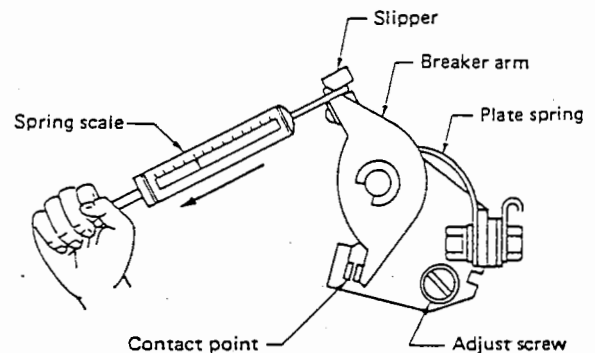

(Fig. 10-4) Measuring the contact pressure of the contact breaker

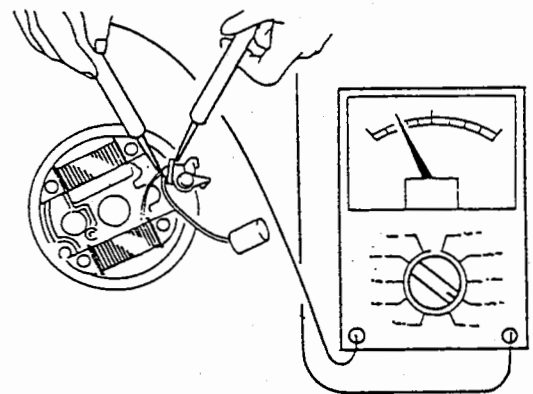

(Fig. 10-5) Measuring insulation of the contact breaker

6. ATTACHING LIGHTING COIL

- 1) Attach the lighting coil to the magneto base plate using two 25mm M5 screws.
 - 1 Locate the coil as shown in the diagram below opposite the ignition coil. Arrange it so that it lies within a circle 96mm \pm 2 in diameter.
 - 2 To assist you the magneto base plate has already been recessed to accept the lighting coil. Move it slightly with your fingers until the core of the

Lighting coil engages with it.

- 2) When the coil has been correctly fitted tape the lighting coil lead to the primary winding and stop wire and secure under the wiring clip. The clip must remain in its original position and not be moved, firmly securing the wires.
Remove unwanted wire clips.

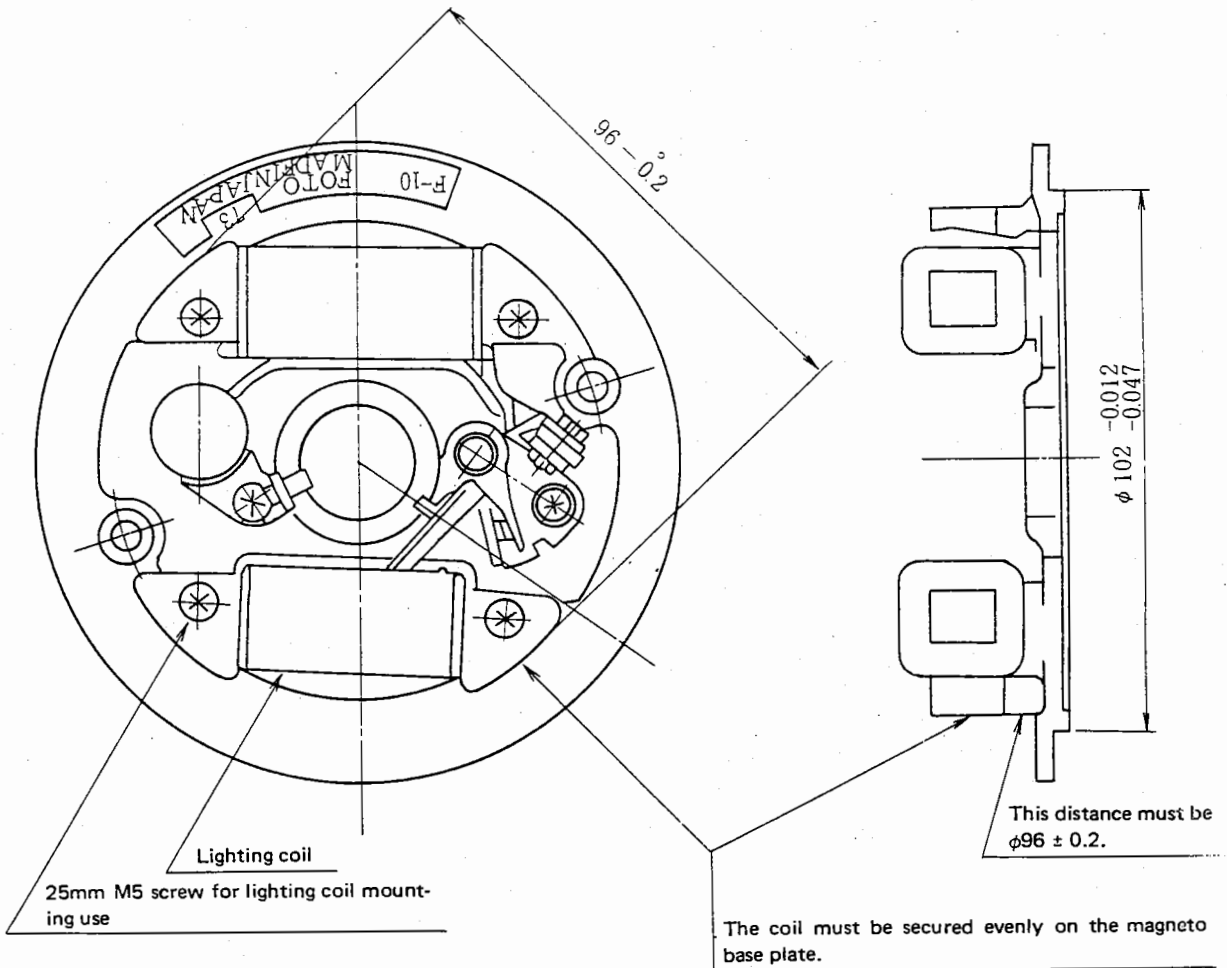

11. SEPARATE TANK KIT

Component Parts List

Part Name	Part Number	Quantity
Fuel Pump	309-04000-0	1
Fuel Pump Nut	9301-1-0300	2
Fuel Pipe Grommet	309-02216-0	1
Fuel Pipe A	309-02211-0	1
Fuel Pipe C	309-02213-0	1
Pulse Nipple	309-01136-0	1
Pulse Nipple Pipe	309-02219-0	1
Pipe Clip	309-70204-0	6
Fuel Adjusting Nozzle	309-04904-0	1
Fuel Tank Assembly	334-70110-1	1
Motor Cover Grommet A	309-67015-0	1
Motor Cover Grommet B	309-67016-0	1

(2) Fuel Adjusting Nozzle Assembly

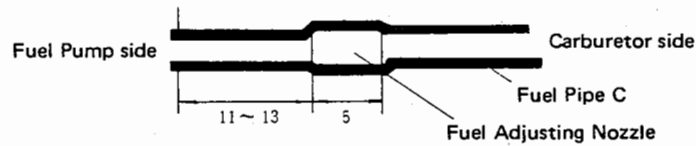

(3) Drawing of Assembly for Other Tank Specifications

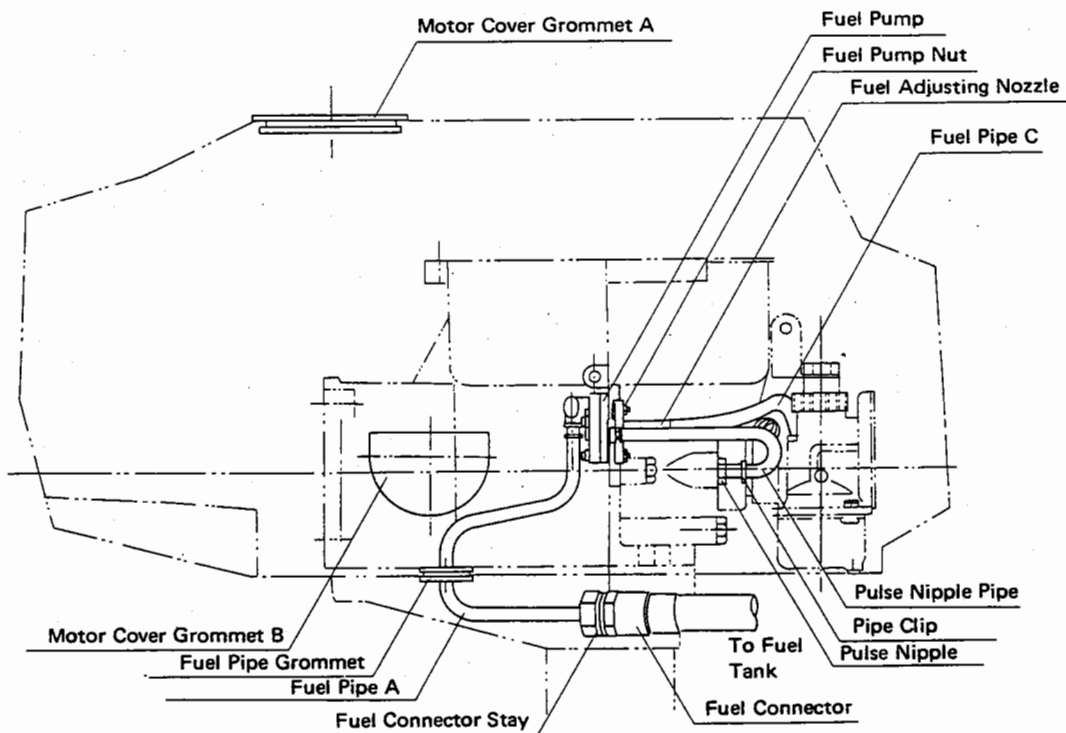

12. BATTERY CHARGING ADAPTER KIT FOR M2.5A/M3.5A

Instructions for attachment and operation

The "Battery Charging Adapter Kit" is used in conjunction with a lighting coil which is provided on most TOHATSU outboard motors for getting a low voltage source of AC power for operating spotlights and navigational lamps. By using the adapter kit, this AC supply can be converted to DC current which can be used for

battery charging and running other electrical equipment that depends on DC current. This chapter describes the kit and explains the manner of attachment to an outboard motor already provided with a lighting coil on the magneto. If the lighting coil is not fitted, one needs to be attached.

(1) Component parts of the battery charging adapter kit

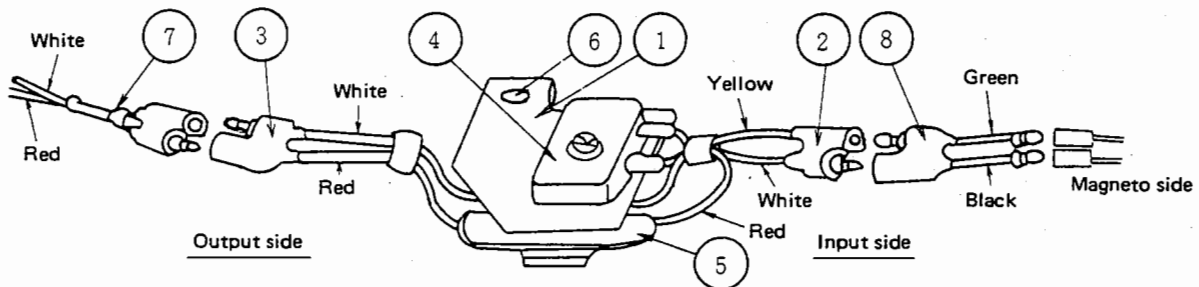

- | | | |
|---------------------|--|--------------------------------|
| (1) Attaching plate | (2) 2P connector (magneto side) | (3) 2P connector (output side) |
| (4) Rectifier | (5) Fuse box (fuse rating: 10A) | (6) Attaching hole |
| (7) Extension cord | (8) Ground cord adapter "A": Male plug "B": Ground cord connection | |

(2) External wiring connections

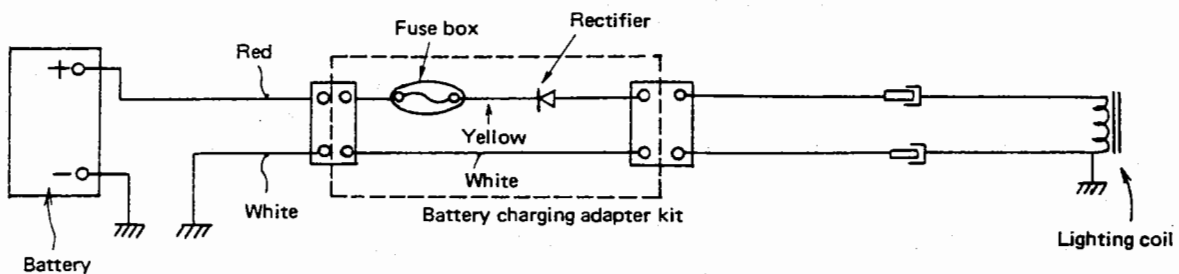

● **M2.5A/M3.5A**

Attach the rectifier complete on the cylinder using a M8 bolt as shown in the figure. Then, fit the lead clamp with the recoil starter bolt. When installing the rectifier complete, be noted that the fuse box side to be inside.

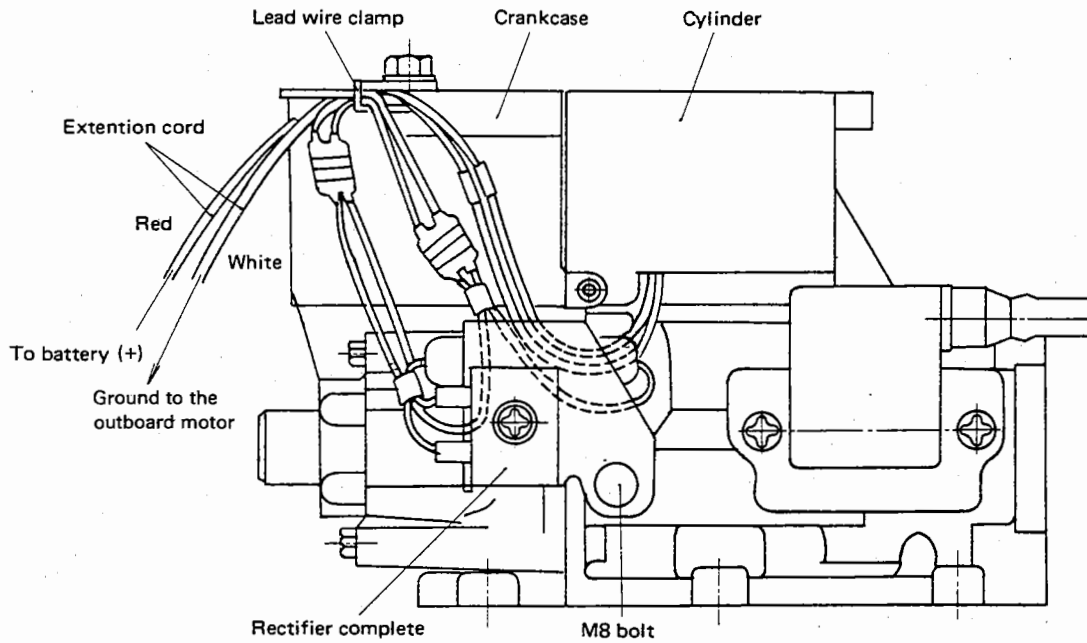

(4) Battery charging circuits

Connect the red wire terminal to the positive (+) terminal of the battery. The white ground wire is attached to the ground connection or the outboard motor. When making this connection, see that the ground terminal connects to bare surface, by removing paint, oil or other materials that would cause a poor conduction. Connect the other end of this wire to the negative (-) terminal of the battery.

In case of M3.5A motor, attach both the ground wire and the extension cord (White) in such manner that they both make a good ground connection to the outboard motor.

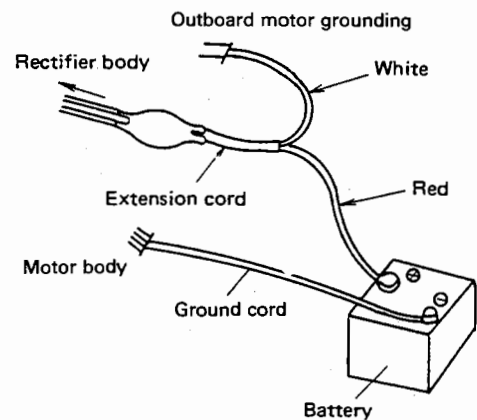

(5) Direct circuits for lighting and battery capacity

If the lights are run without the battery being connected, the lighting coil will have a much greater output than when the battery is connected. In this case the lights would be connected to the 2P connector, which has yellow and white lead wires.

The capacity of a battery for outboard use is determined by the charging performance of the charging unit, the using conditions of the outboard and the value of the

connected load, i.e., the number of lamps in circuit. See the following table for your reference when using lamps and battery.

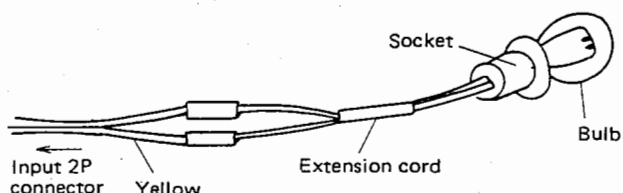

Model	Recommended electric lamp load (Battery connected)	Recommended electric lamp load (Directly connected to the lighting coil)	Recommended battery capacity
M2.5A/M3.5A	12V-35W	12V-40W	12V 30 - 35Ah

(6) Checking the battery charging adapter kit

a. Fuse

The fuse protects the equipment from damage due to improper battery wiring or connections, or from short circuits. A 10 Amp. rated fuse must be used. When inspecting the fuse, first open the fuse box and check its condition visually. The holding screws must be tight and connections clean and free from corrosion or deformation. If necessary check the connection using a tester. Clean or repair as necessary.

b. Rectifier

First check the condition of the fuse. When this is found to be satisfactory next check the rectifier using the resistance measuring range of a standard radio multi-tester.

Measuring the resistance between the male plug on the 2P connector, input side (Yellow lead) and the female socket, output side (Red lead) and check against the following table.

The rectifier will be considered serviceable if the tester pointer vibrates slightly indicating high resistance when carrying out test method (2) or if the tester pointer vibrates greatly indicating low resistance when carrying out test method (1).

As the vibration states vary according to the type of tester employed and the range used. However, the oscillation of the meter pointer in either method indicates that the rectifier should perform normally.

Items	Testing method (1) Test terminal	Testing method (2) Test terminal
Input side (2P connector) male (Yellow)	(+)	(-)
Output side (2P connector) female (Red)	(-)	(+)

IV. TROUBLE SHOOTING AND SERVICING M2.5A/M3.5A

1. TROUBLE SHOOTING

Possible causes in engine troubles are listed below. For checking and repairing the engine, refer to this table.

Engine does not start.	Engine starts but stops soon.	Poor idling.	Engine revolutions abnormally high.	Engine revolutions abnormally low.	Slow speed.	Overheating of engine.	Possible causes
<input type="checkbox"/>	<input type="checkbox"/>						Empty fuel tank
<input type="checkbox"/>	<input type="checkbox"/>						Incorrect connection of fuel system
<input type="checkbox"/>	<input type="checkbox"/>	<input type="checkbox"/>		<input type="checkbox"/>	<input type="checkbox"/>	<input type="checkbox"/>	Air entering fuel line
<input type="checkbox"/>	<input type="checkbox"/>	<input type="checkbox"/>		<input type="checkbox"/>	<input type="checkbox"/>	<input type="checkbox"/>	Distorted fuel pipe
<input type="checkbox"/>	<input type="checkbox"/>	<input type="checkbox"/>		<input type="checkbox"/>	<input type="checkbox"/>	<input type="checkbox"/>	Air vent on fuel tank closed
<input type="checkbox"/>	<input type="checkbox"/>	<input type="checkbox"/>		<input type="checkbox"/>	<input type="checkbox"/>	<input type="checkbox"/>	Clogged fuel filter, fuel pump, or carburetor
<input type="checkbox"/>	<input type="checkbox"/>	<input type="checkbox"/>		<input type="checkbox"/>	<input type="checkbox"/>	<input type="checkbox"/>	Improper engine oil
<input type="checkbox"/>	<input type="checkbox"/>	<input type="checkbox"/>		<input type="checkbox"/>	<input type="checkbox"/>	<input type="checkbox"/>	Use of improper gasoline
<input type="checkbox"/>	<input type="checkbox"/>	<input type="checkbox"/>		<input type="checkbox"/>	<input type="checkbox"/>	<input type="checkbox"/>	Excessive oil in mixture
<input type="checkbox"/>	<input type="checkbox"/>	<input type="checkbox"/>		<input type="checkbox"/>	<input type="checkbox"/>	<input type="checkbox"/>	Shortage of oil in mixture
<input type="checkbox"/>	<input type="checkbox"/>	<input type="checkbox"/>		<input type="checkbox"/>	<input type="checkbox"/>	<input type="checkbox"/>	Excessive supply of fuel
<input type="checkbox"/>	<input type="checkbox"/>	<input type="checkbox"/>		<input type="checkbox"/>	<input type="checkbox"/>	<input type="checkbox"/>	Poor carburetor adjustment
<input type="checkbox"/>	<input type="checkbox"/>	<input type="checkbox"/>		<input type="checkbox"/>	<input type="checkbox"/>	<input type="checkbox"/>	Water circulation pipe broken
<input type="checkbox"/>	<input type="checkbox"/>	<input type="checkbox"/>		<input type="checkbox"/>	<input type="checkbox"/>	<input type="checkbox"/>	Spark plug other than BP6HS-10 employed
<input type="checkbox"/>	<input type="checkbox"/>	<input type="checkbox"/>		<input type="checkbox"/>	<input type="checkbox"/>	<input type="checkbox"/>	Dirty or shorting spark plug
<input type="checkbox"/>	<input type="checkbox"/>	<input type="checkbox"/>		<input type="checkbox"/>	<input type="checkbox"/>	<input type="checkbox"/>	Weak or no spark
<input type="checkbox"/>	<input type="checkbox"/>	<input type="checkbox"/>		<input type="checkbox"/>	<input type="checkbox"/>	<input type="checkbox"/>	Dirty contact points
<input type="checkbox"/>	<input type="checkbox"/>	<input type="checkbox"/>		<input type="checkbox"/>	<input type="checkbox"/>	<input type="checkbox"/>	Incorrect connection of high tension cables
<input type="checkbox"/>	<input type="checkbox"/>	<input type="checkbox"/>		<input type="checkbox"/>	<input type="checkbox"/>	<input type="checkbox"/>	Insufficient cooling water flow
<input type="checkbox"/>	<input type="checkbox"/>	<input type="checkbox"/>	<input type="checkbox"/>	<input type="checkbox"/>	<input type="checkbox"/>	<input type="checkbox"/>	Cavitation
<input type="checkbox"/>	<input type="checkbox"/>	<input type="checkbox"/>	<input type="checkbox"/>	<input type="checkbox"/>	<input type="checkbox"/>	<input type="checkbox"/>	Incorrect propeller fitting
<input type="checkbox"/>	<input type="checkbox"/>	<input type="checkbox"/>	<input type="checkbox"/>	<input type="checkbox"/>	<input type="checkbox"/>	<input type="checkbox"/>	Damaged or bent propeller
<input type="checkbox"/>	<input type="checkbox"/>	<input type="checkbox"/>	<input type="checkbox"/>	<input type="checkbox"/>	<input type="checkbox"/>	<input type="checkbox"/>	Improper thrust rod position
<input type="checkbox"/>	<input type="checkbox"/>	<input type="checkbox"/>	<input type="checkbox"/>	<input type="checkbox"/>	<input type="checkbox"/>	<input type="checkbox"/>	Unbalanced load position
<input type="checkbox"/>	<input type="checkbox"/>	<input type="checkbox"/>	<input type="checkbox"/>	<input type="checkbox"/>	<input type="checkbox"/>	<input type="checkbox"/>	Transom too high or low
<input type="checkbox"/>	<input type="checkbox"/>	<input type="checkbox"/>	<input type="checkbox"/>	<input type="checkbox"/>	<input type="checkbox"/>	<input type="checkbox"/>	Short-circuit of engine stop switch

2. PROPELLER SETTING

The propeller is an important part of the out-board motor and a variety of types are available to suit different purposes.

○ SELECTION OF A PROPELLER

In order that engine power can be effectively used to propel the vessel, it is necessary to select a propeller best suitable to the purpose for which the boat will be used. Normally, a propeller having a small outer diameter and a large pitch is suitable for a high-speed vessel. For heavier vessels, a propeller having a large outer diameter and a small pitch running at constant engine revolutions is recommended.

Recommended engine speed: 4,300~5,000 rpm (M3.5A)
3,800~5,200 rpm (M2.5A)

For the specifications of the recommended propellers to be used for each model, refer to the attached service data.

○ PRECAUTION TO BE TAKEN WHEN MOUNTING THE PROPELLER:

Lubricate the propeller shaft with the Tohatsu grease to prevent it from salt-damage.

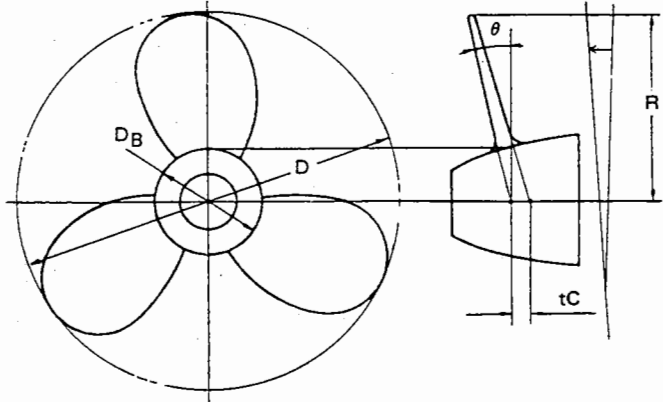

Fig. 15-1 Particulars of propeller

- D: Diameter
- R: Radius
- DB: Boss diameter
- H: Pitch
- θ : Tilt angle of rake
- tC: Imaginary thickness on center line
- Z: Number of blades
- Pitch ratio: N/D
- Boss ratio: DB/D
- Blades thickness ratio (B.T.R.): tC/D

CHECK

Damage: Repair or replace as necessary.

Wear: Replace, when necessary.

Propeller Size

Model	Type	Nos. of Blade x D x P
M2.5A		3 x 188 mm x 110 mm
M3.5A	A	2 x 180 mm x 166 mm

3. TEST RUNNING

Check the engine and lower unit as follows after assembling.

○ ITEMS TO BE CHECKED BEFORE TRIAL RUN

- * Electrical wiring, connections, clamps

○ ITEMS TO BE CHECKED DURING TRIAL RUN

After starting the engine, check the following items while idling.

- * Fuel leaks from fitting face of crank case.
- * Fuel leaks from mounting face of intake manifold assembly.
- * Cooling water leaks from fitting face of cylinder head.
- * Cooling water leaks from mounting face of engine.
- * Abnormal noises and vibration.
- * Idling revolutions and even running.
- * Discharge condition of cooling water. (discharge of cooling water from water detecting hole)
- * Stop switch operation.
- * Engine revolutions at slow and abrupt acceleration time.

○ CLAMPING AFTER TRIAL RUN:

Perform additional clamping at the specified torque without fail after trial run. For the clamping torque, see "Clamping torque list".

○ RUNNING-IN PERIOD

After the piston, piston ring, piston pin, crank shaft, cylinder assembly and/or bevel gears have been replaced, a running-in period should be observed for the purpose of smoothly seating the sliding surfaces of all the moving parts.

Remarks:

Mixing ratio of gasoline to engine oil: 20 : 1 (After an engine part has been changed.)

Running-in period: 10 hours

Revolutions: Low and medium speed running without fully opening the throttle. Vary the throttle speed from time to time.

STATIC RUNNING WITH TEST PROPELLER

The test propeller has been designed so that outboard motors can be tested on land in a tank stimulating running conditions. It provides a suitable load for the engine.

1. Its main purposes are for:

- a) Breaking in a new or recently-overhauled unit.
- b) Adjusting and checking a unit under running conditions.

2. Water tank

- a) Minimum tank dimensions are given in Fig. 16-2.
- b) When two motors are operated in one tank they should be separated by a baffle plate.
- c) Continuous use may cause the water temperature to

rise which could cause the engine to seize. The water temperature should not be permitted to exceed 25°C. Water temperature can be regulated by a cooling device, or by using a cold water source and overflow system.

- d) Fresh water must be used at all times. Dirty water can result in cooling water passages becoming clogged and cooling performance can deteriorate.
- e) Continuous running may result in exhaust gases entering the carburetor air intake, so affecting the mixture. It is therefore necessary to arrange exhaust fans or other methods to remove exhaust fumes from the testing area.
- f) Ensure that the water level in the tank is always maintained at the correct level during trial runs to prevent splashing.

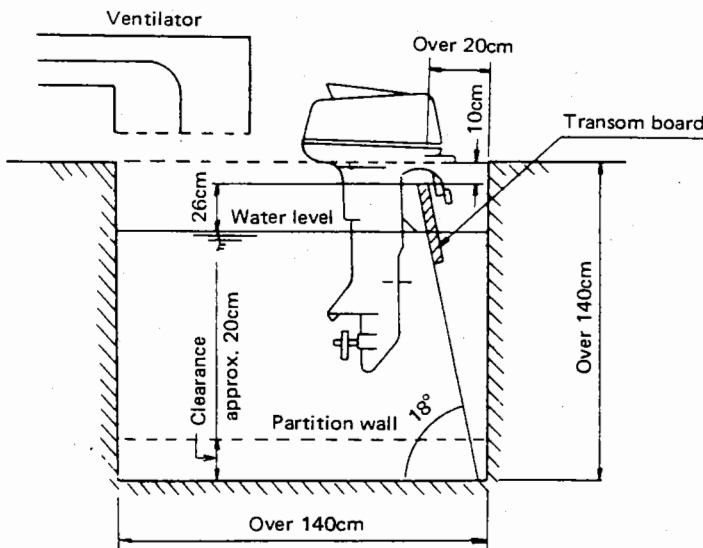
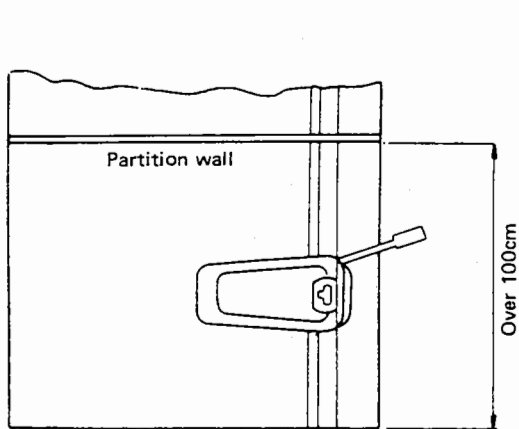

Fig. 16-2 Water tank

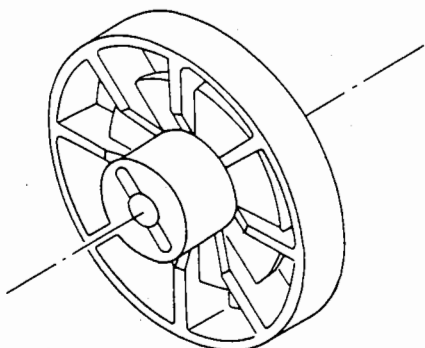

Fig. 16-3 Test propeller

Size of Test Propeller

Model	Thickness (mm)	Outside Dia. (mm)
M5A2	15	114
M3.5A	15	118

4. SERVICE DATA OF M2.5A/M3.5A

Note: Unit in millimeter unless otherwise specified.

Part name	Items	Standard value	Limit for adjustment or replacement	
Engine	Piston	Clearance between piston and cylinder wall (minimum clearance).	0.06 ~ 0.09	0.15 and over
	Cylinder	Bore	47.00 ~ 47.01	47.05 and over
	Cylinder head	Deformation of attaching face		0.05 and over
	Piston ring	Gap between piston ring ends	0.18 ~ 0.33	0.9 and over
		Clearance with piston ring groove	0.01 ~ 0.05	0.1 and over
	Piston pin	Clearance with piston ring pin hole	0.001 ~ 0.016	0.05 and over
	Connecting rod	Small end deflection (in the axial direction)	0.6 ~ 0.8	1.5 and over
		Big end side gap	0.13 ~ 0.32	0.5 and over
	Crank shaft	Off-centering of crank shaft	Less than 0.05	0.05 and over
	Reed valve	Lift (height of the reed valve stopper end)	6.0 ~ 6.2	6.0 ~ 6.2 and over
Cylinder compression	Measure cylinder compression (after warming up the engine)	5.5 kg/cm ² and over	Less than 4 kg/cm ²	
Oil seal	Crank shaft oil seal upper inside dia. Crank shaft oil seal upper inside dia.	18.8 ~ 19.2 13.5 ~ 13.9	If the lip portion is aged or if the rubber has lost its resilience or if it makes a slack fit with the shaft then it must be replaced.	
Fuel system	Carburetor	Venturi tube dia.	φ 13	
		Main jet	# 88	
		Jet needle	0.71-1/2	
		Needle jet	# 80	
		Cut away	0.75	
		Valve seat dia.	φ 1.4	
Float engine set (From packing surface)	2.0			
Electrical equipment	Magneto	Point gap	0.3-0.4	
		Ignition coil resistance	Primary 0.95Ω ± 15% Secondary 5000Ω ± 15%	
	Exciter coil	1.5Ω		
	Spark plug	NGK BP6HSIO CHAMPION L87YC10	Spark plug gap 0.9~1.0 mm 0.9~1.0 mm	Less or over 0.9~1.0 Less or over 0.9~1.0

5. SEALING, BONDING AND LUBRICATION POINTS M2.5A/M3.5A

A. ENGINE

	Screw-lock	Screw-lock super No. 103Q	Screw-lock super No. 101Q	Cup grease	Mobile grease No. 22	Tohatsu genuine oil	Tohatsu genuine gear oil	Molybdenum disulfide	Three-bond No. 4-1	Three-bond No. 7	Screw-lock	Remarks
Fitting face of cylinder and crank case									○			Be careful with coating thickness.
Cylinder head gasket										○		Circumference of skirt ring
Piston						○						Total circumference
Piston pin						○						
Piston ring A, B						○						
Cylinder liner						○						
Main bearing A, B						○						
Oil seal A				○								Lip
Oil seal B				○								Lip
Crank case cover oil seal				○								Lip
Needle roller bearing at connecting rod small end						○						
Needle roller bearing at connecting rod big end						○						
Throttle cable						○						Clearance from outer face
Starter spring					○							
Ratchet					○							
Both surfaces of engine base gasket										○		
Check valve screw											○	Lip
Engine base oil seal												
Gear case bolt	○											
Gear case lid bolt	○											
Gear case lubrication oil							○					
Fitting face of lower drive shaft housing of gear case									○			Be careful with coating thickness.
Propeller shaft oil seal					○							Lip
Propeller shaft					○							Propeller mounting portion after assembling
Drive shaft oil seal					○							Lip
Clamp screw					○							Screw and shaft
Thrust washer					○							Both surface A, B
Tilt stopper bushing					○							Shaft slide portion
Steering shaft bushings A, B					○							

B. LOWER UNIT

	Screw-lock	Screw-lock super No. 103Q	Screw-lock super No. 101Q	Cup grease	Tohatsu grease	Tohatsu genuine oil	Tohatsu genuine gear oil	Molybdenum disulfide	Three-bond No. 4-1	Three-bond No. 7	Screw-lock	Remarks
Tilt stopper bolt	○											
Spacer nut		○										
Steering handle					○							Throttle grip mounting portion
Steering handle bolts A, B					○							Shaft (Not screw portion)
Steering handle bolt washer					○							Slide piece (inner face)
Steering handle bolt fitting metal C					○							Single face opposite to ratchet
Throttle grip spring					○							
Sliding piece of throttle grip					○							
Lock lever shaft					○							Shaft slide portion
Reverse lock lever					○							Hole slide portion
Link holder					○							Hole slide portion
Shift rod connecting arm					○							Hole slide portion
Shift rod connecting arm shaft		○			○							Screw portion
Shift lever spring					○							Hole and face
Shift lever stopper plate					○							
Shift lever shaft collar					○							
Steering bracket bolt	○											
Choke lever shaft					○							Slide portion
Drive shaft								○				Spline-on engine side when assembling

V. PERIODICAL CHECK

CHECK ITEM	MAINTENANCE FREQUENCY	ITEM & ACTION TO BE TAKEN	REMARKS
Check nuts & bolts for correct tightness	New engine after 10 hrs operation.	Locations: Cylinder head, carburetor, intake manifold, crank case, starter, drive shaft housing, bearing housing, gear case, etc.	
Spark plug	Every 30 hrs	Remove carbon, clean and adjust electrodes to correct gap. Replace if electrodes are worn or insulation cracked or chipped.	NGK BP6HS-10 CHAMPION L87YC-10 Plug gap: 0.9~1.0 mm
Fuel system	Every 50 hrs	Clean dirt and water from fuel tank, fuel pipes, fuel pump and the float chamber of the carburetor and inspect for damage and fuel leaks.	Clean pipe lines etc., by clean air blast.
Decarbonizing	Every 100 hrs	Remove carbon from the combustion chamber, exhaust manifold, piston ring grooves, etc.	
Carburetor	Every 100 hrs	Strip and clean with air blast. Check for wear in spindles and clean jets and passage ways with air blast. Check float level.	Symptoms: Poor idling, low & medium speed operation.
Propeller	In every use	Check condition. Repair or replace if necessary.	
Starter rope	In every use	Inspect for damage or wear.	
Cooling water passages	Every 100 hrs	Remove fur and sediment from the cooling water pump passages, the cooling water pipe, cylinder block and cylinder head.	Symptoms: Overheating due to poor cooling water circulation.
Cooling water check	During use	Ensure that the cooling water is circulation by noting discharge from port. See that inlet is free from blockage.	
Gear oil	a) Change oil after 10 hrs initial run. b) fill up the shortage after every 50 hrs run, c) and change oil after every 200 hrs run, and also after prolonged winter storage when the new season starts.	Following the changing instruction given below. Top-up oil as necessary and inspect for oil leakages around propeller shaft oil seal etc., cracks and signs of wear.	TOHATSU gear oil (GL-5 SAE #80~90)
Grease up	Every 50 hrs	Propeller shaft, handle, recoil starter, shift lever shaft, shift lever lock plate, carburetor choke rod, choke lever, reverse lock mechanism, and other moving parts.	

CHECK ITEM	MAINTENANCE FREQUENCY	ITEM & ACTION TO BE TAKEN	REMARKS
Cylinder compression	Every 100 hrs	Measure cylinder compression after warming-up.	See Service Data.
Clutch operation	At every operation	Check for correct clutch play and engagement.	
Reverse lock operation	At every operation	Check for correct lock.	
Tilt up operation	Every 100 hrs	Adjust by tightening bracket bolt.	
Stop switch operation	Check daily	Confirmation of normal short-circuit operation.	
Leads and pipes	Check daily	Connectors, clamps Pipes and leads for damage.	
Leakage of lubricating oil	Check daily	Bearing housing lubricating port, drain oil port.	
Leakage of gasoline	Check daily	Carburetor, fuel tank Crank case	
Start-up	At every operation	Engine start-up Choke lever and throttle lever operation.	
Accelerating condition	At every operation	Check for smoothness or knocking when gradually accelerating the engine from idling. Check for smoothness or stalling when rapidly accelerating or decelerated.	After warming-up.
Anodes	Every 100 hrs	a) Engine anode: Check for wear. b) Gearcase anode: Check for wear and deformation.	Gearcase trim tab is used as anode.

 **TOHATSU CORPORATION**

Address: 4-9, 3-chome, Azusawa, Itabashi-ku, TOKYO 174, Japan

Cable: "TOHATSU TOKYO"

Telex: 272-2051 THT J

Facsimile: TOKYO (03) 969-7885 (GII-GIII)

Phone: TOKYO (03) 966-3111

Printed in Japan
003-21016-0